

PRODUCT SPECIFICATIONS



16 SEER
R-410A

COOLING CAPACITY: 24,000 - 57,000 BTU/h

HEATING CAPACITY: 24,000 - 57,000 BTU/h



Online registration is required within 60 days of installation.



ASZ16
SPLIT SYSTEM HEAT PUMP

The Amana[®] brand ASZ16 Heat Pumps offer energy efficiencies and operating sound levels that are among the best in the heating and cooling industry. Our quality manufacturing, easy installation and maintenance make this unit one of the best values on the market.

Standard Features

- R-410A environmentally friendly refrigerant
- Two-Stage Copeland[®] UltraTech Scroll compressor
- High-density foam compressor cover
- Copeland[®] ComfortAlert diagnostics
- High- and low-pressure switches
- Fully charged for 15' of tubing length
- Factory-installed bi-flow liquid line filter dryer
- Liquid refrigerant return protection
- Two-speed condenser fan motor
- Copper tubing/enhanced aluminum fin coil
- Sweat connection service valves with easy access to gauge ports
- ARI Certified; ETL Listed

Cabinet Features

- Unique Amana[®] brand sound control top design
- Wire fan discharge grille
- Steel louver coil guard
- Baked-on powder paint finish
- Rust-resistant coated screws
- Compact footprint
- Top and side maintenance access
- Single-panel access to controls with space provided for field-installed accessories
- When properly anchored, meets 2001 Florida Building Code unit integrity requirements for hurricane-type winds (Anchor bracket kits available.)

Contents

Nomenclature..... 2
 Product Specifications..... 3
 Expanded Cooling Data 4
 Expanded Heating Data.....20
 ARI Performance Ratings.....22
 Dimensions.....26
 Wiring Diagram27
 Accessories28

NOMENCLATURE

	A	S	Z	16	036	1	AA	
	1	2	3	4,5	6,7,8	9	10,11	
Brand	A Amana® Brand						Engineering *	
							Major/ Minor Revisions	
							* Neither revision is used for order entry or inventory management.	
Product Category	S Split System							
Unit Type	C Condenser R-22							
	X Condenser R-410A							
	H Heat Pump R-22							
	Z Heat Pump R-410A							
Efficiency	13 13 SEER							
	14 14 SEER							
	16 16 SEER							
	18 18 SEER							
						Electrical		
						1	208/230 V, 1 Phase, 60 Hz	
						2	220/240 V, 1 Phase, 50 Hz	
						3	208/230 V, 3 Phase, 60 Hz	
						4	460 V, 3 Phase, 60 Hz	
						5	380/415 V, 3 Phase, 50 Hz	
						Nominal Capacity		
	018		1½ Tons		048		4 Tons	
	024		2 Tons		060		5 Tons	
	030		2½ Tons		090		7½ tons	
	036		3 Tons		120		10 Tons	
	042		3½ Tons					

Important EnergyStar Notice: Proper sizing and installation of equipment is critical to achieve optimal performance. Split system air conditioners and heat pumps must be matched with appropriate coil components to meet EnergyStar criteria. Ask your contractor for details or visit www.energystar.gov.

SPECIFICATIONS

	ASZ16 0241A	ASZ16 0361A	ASZ16 0481A	ASZ16 0481B	ASZ16 0601A
Capacities and Ratings					
Nominal Cooling (BTU/h)	24,000	36,000	48,000	48,000	60,000
Nominal Heating (BTU/h)	24,000	36,000	48,000	48,000	60,000
Decibels	72	73	74	74	75
Compressor					
RLA	10.3	16.7	21.2	21.1	25.6
LRA	52	82.0	96.0	96.0	118.0
Condenser Fan Motor					
Horsepower	1/6	1/6	1/6	1/6	1/6
FLA	1	1	1	1	1
Refrigeration System					
Refrigerant Line Size ¹					
Liquid Line Size ("O.D.)	3/8"	3/8"	3/8"	3/8"	3/8"
Suction Line Size ("O.D.)	3/4"	7/8"	1 1/8"	1 1/8"	1 1/8"
Refrigerant Connection Size					
Liquid Valve Size ("O.D.)	3/8"	3/8"	3/8"	3/8"	3/8"
Suction Valve Size ("O.D.)	3/4"	7/8"	7/8"	7/8"	7/8"
Valve Connection Type	Sweat	Sweat	Sweat	Sweat	Sweat
Refrigerant Charge	160	210	270	270	280
Shipped with Orifice Size	NA	NA	NA	NA	NA
Electrical Data					
Volts / Hz / Phase	208/230-60-1				
Minimum Circuit Ampacity ²	13.9	21.9	27.5	27.4	33
Max. Overcurrent Protection ³	20	30	40	40	50
Min / Max Volts	197/253	197/253	197/253	197/253	197/253
Power Supply Conduit Size	1/2" or 3/4"	1/2" or 3/4"	1/2" or 3/4"	1/2" or 3/4"	1/2" or 3/4"
Ship Weight (lbs)	282	282	282	282	296

¹ Tested and rated in accordance with ARI Standard 210/240

² Wire size should be determined in accordance with National Electrical Codes; extensive wire runs will require larger wire sizes

³ Must use time-delay fuses or HACR-type circuit breakers of the same size as noted.

Notes

- Always check the S&R plate for electrical data on the unit being installed.
- Installer will need to supply 7/8" to 1 1/8" adapters for suction line connections.
- Unit is charged with refrigerant for 15' of 3/8" liquid line. System charge must be adjusted per Installation Instructions Final Charge Procedure.
- Installation of these units requires the specified TXV Kit to be installed on the indoor coil. THE SPECIFIED TXV IS DETERMINED BY THE OUTDOOR UNIT NOT THE INDOOR COIL.

EXPANDED COOLING DATA — ASZ160241A* / CA*F3636*6A* + TXV / MBE1600** -1 LOW STAGE

IDB	Airflow	Outdoor Ambient Temperature																							
		65°F				75°F				85°F				95°F				105°F				115°F			
		59	63	67	71	59	63	67	71	59	63	67	71	59	63	67	71	59	63	67	71	59	63	67	71
70	MBh	17.7	18.3	20.1	-	17.3	17.9	19.6	-	16.9	17.5	19.2	-	16.5	17.1	18.7	-	15.6	16.2	17.8	-	14.5	15.0	16.5	-
	S/T	0.79	0.66	0.46	-	0.82	0.68	0.47	-	0.84	0.70	0.48	-	0.86	0.72	0.50	-	0.90	0.75	0.52	-	0.90	0.76	0.52	-
	ΔT	18	15	12	-	18	15	12	-	18	15	12	-	18	15	12	-	18	15	12	-	16	14	11	-
	kW	1.06	1.09	1.12	-	1.15	1.17	1.21	-	1.22	1.25	1.29	-	1.29	1.32	1.36	-	1.34	1.37	1.42	-	1.39	1.42	1.47	-
	Amps	4.2	4.3	4.4	-	4.5	4.6	4.8	-	4.9	5.0	5.2	-	5.2	5.3	5.5	-	5.6	5.7	5.9	-	5.9	6.0	6.2	-
	Hi PR	209	225	237	-	235	252	266	-	267	287	303	-	304	327	345	-	342	368	388	-	378	406	429	-
	Lo PR	113	121	132	-	120	127	139	-	124	132	144	-	131	139	152	-	137	146	159	-	142	151	164	-
	MBh	17.2	17.8	19.5	-	16.8	17.4	19.1	-	16.4	17.0	18.6	-	16.0	16.6	18.2	-	15.2	15.7	17.2	-	14.1	14.6	16.0	-
	S/T	0.75	0.63	0.43	-	0.78	0.65	0.45	-	0.80	0.67	0.46	-	0.82	0.69	0.48	-	0.86	0.71	0.50	-	0.86	0.72	0.50	-
	ΔT	19	16	12	-	19	16	12	-	19	16	12	-	19	16	12	-	19	16	12	-	18	15	12	-
731	kW	1.06	1.08	1.11	-	1.14	1.16	1.20	-	1.21	1.24	1.28	-	1.28	1.31	1.35	-	1.33	1.36	1.41	-	1.38	1.41	1.46	-
	Amps	4.1	4.2	4.4	-	4.5	4.6	4.7	-	4.8	5.0	5.1	-	5.2	5.3	5.5	-	5.5	5.6	5.8	-	5.8	6.0	6.2	-
	Hi PR	207	223	235	-	232	250	264	-	264	284	300	-	301	324	342	-	338	364	384	-	374	402	425	-
	Lo PR	112	119	130	-	118	126	138	-	123	131	143	-	129	138	150	-	136	144	157	-	140	149	163	-
	MBh	16.3	16.9	18.5	-	15.9	16.5	18.1	-	15.6	16.1	17.7	-	15.2	15.7	17.2	-	14.4	15.0	16.4	-	13.4	13.9	15.2	-
	S/T	0.72	0.60	0.42	-	0.75	0.62	0.43	-	0.77	0.64	0.44	-	0.79	0.66	0.46	-	0.82	0.68	0.47	-	0.83	0.69	0.48	-
	ΔT	19	16	12	-	19	17	13	-	19	17	13	-	19	17	13	-	19	17	13	-	18	15	12	-
	kW	1.04	1.06	1.10	-	1.12	1.14	1.18	-	1.19	1.22	1.26	-	1.26	1.28	1.33	-	1.31	1.34	1.38	-	1.36	1.39	1.43	-
	Amps	4.1	4.2	4.3	-	4.4	4.5	4.6	-	4.8	4.9	5.0	-	5.1	5.2	5.4	-	5.4	5.5	5.7	-	5.7	5.9	6.1	-
	Hi PR	203	218	230	-	228	245	259	-	259	278	294	-	295	317	335	-	332	357	377	-	366	394	416	-
Lo PR	110	117	128	-	116	124	135	-	121	128	140	-	127	135	147	-	133	141	154	-	137	146	160	-	

75	MBh	18.0	18.5	20.1	21.5	17.6	18.1	19.6	21.0	17.2	17.7	19.1	20.5	16.7	17.2	18.7	20.0	15.9	16.4	17.7	19.0	14.7	15.2	16.4	17.6
	S/T	0.90	0.80	0.61	0.39	0.93	0.83	0.63	0.40	0.95	0.85	0.64	0.41	0.98	0.88	0.67	0.43	1.00	0.91	0.69	0.44	1.00	0.92	0.70	0.45
	ΔT	20	19	15	11	21	19	15	11	21	19	15	11	21	19	16	11	20	19	15	11	19	18	14	10
	kW	1.07	1.10	1.13	1.17	1.16	1.18	1.22	1.26	1.23	1.26	1.30	1.35	1.30	1.33	1.37	1.42	1.36	1.39	1.43	1.48	1.40	1.44	1.48	1.54
	Amps	4.2	4.3	4.5	4.6	4.6	4.7	4.8	5.0	4.9	5.1	5.2	5.4	5.3	5.4	5.6	5.8	5.6	5.7	5.9	6.2	5.9	6.1	6.3	6.5
	Hi PR	211	227	240	250	237	255	269	281	269	290	306	319	307	330	349	364	345	372	392	409	381	410	433	452
	Lo PR	114	122	133	142	121	129	140	150	126	134	146	155	132	140	153	163	138	147	161	171	143	152	166	177
	MBh	17.5	18.0	19.5	20.9	17.1	17.6	19.0	20.4	16.7	17.2	18.6	19.9	16.3	16.7	18.1	19.4	15.4	15.9	17.2	18.5	14.3	14.7	15.9	17.1
	S/T	0.85	0.76	0.58	0.37	0.89	0.79	0.60	0.39	0.91	0.81	0.61	0.40	0.94	0.84	0.63	0.41	0.97	0.87	0.66	0.42	0.98	0.88	0.66	0.43
	ΔT	22	20	16	11	22	20	16	11	22	20	16	11	22	20	17	11	22	20	16	11	20	19	15	11
731	kW	1.06	1.09	1.12	1.16	1.15	1.17	1.21	1.25	1.22	1.25	1.29	1.34	1.29	1.32	1.36	1.41	1.34	1.37	1.42	1.47	1.39	1.42	1.47	1.52
	Amps	4.2	4.3	4.4	4.6	4.5	4.6	4.8	4.9	4.9	5.0	5.2	5.4	5.2	5.3	5.5	5.7	5.6	5.7	5.9	6.1	5.9	6.0	6.2	6.5
	Hi PR	209	225	238	248	235	252	267	278	267	287	303	316	304	327	345	360	342	368	388	405	378	406	429	448
	Lo PR	113	121	132	140	120	127	139	148	124	132	144	154	131	139	152	162	137	146	159	169	142	151	165	175
	MBh	16.6	17.1	18.5	19.9	16.2	16.7	18.1	19.4	15.8	16.3	17.6	18.9	15.4	15.9	17.2	18.5	14.7	15.1	16.3	17.5	13.6	14.0	15.1	16.3
	S/T	0.82	0.73	0.55	0.36	0.85	0.76	0.57	0.37	0.87	0.78	0.59	0.38	0.90	0.80	0.61	0.39	0.93	0.83	0.63	0.41	0.94	0.84	0.64	0.41
	ΔT	22	20	17	11	22	20	17	12	22	20	17	12	22	21	17	12	22	20	17	12	21	19	16	11
	kW	1.05	1.07	1.10	1.14	1.13	1.15	1.19	1.23	1.20	1.23	1.27	1.31	1.27	1.29	1.34	1.38	1.32	1.35	1.40	1.44	1.37	1.40	1.45	1.50
	Amps	4.1	4.2	4.3	4.5	4.4	4.5	4.7	4.9	4.8	4.9	5.1	5.3	5.1	5.3	5.4	5.6	5.5	5.6	5.8	6.0	5.8	5.9	6.1	6.3
	Hi PR	205	220	233	243	230	247	261	272	261	281	297	310	298	320	338	353	335	360	381	397	370	398	421	439
Lo PR	111	118	129	137	117	125	136	145	122	130	142	151	128	136	149	158	134	143	156	166	139	148	161	172	

IDB: Entering Indoor Dry Bulb Temperature kW = Total system power Shaded area is ACCA (TVA) conditions Amps = outdoor unit amps (comp.+fan)
 High and low pressures are measured at the liquid and suction service valves.

EXPANDED COOLING DATA — ASZ160241A* / CA*F3636*6A* + TXV / MBE1600** -1 LOW STAGE (CONT.)

IDB	Airflow	Outdoor Ambient Temperature																								
		65°F				75°F				85°F				95°F				105°F				115°F				
		59	63	67	71	59	63	67	71	59	63	67	71	59	63	67	71	59	63	67	71	59	63	67	71	
80	731	MBh	18.3	18.7	20.0	21.4	17.9	18.3	19.5	20.9	17.5	17.8	19.1	20.4	17.0	17.4	18.6	19.9	16.2	16.5	17.7	18.9	15.0	15.3	16.4	17.5
		S/T	1.00	0.92	0.75	0.56	1.00	0.95	0.78	0.58	1.00	1.00	0.80	0.60	1.00	1.00	0.82	0.61	1.00	1.00	0.85	0.64	1.00	1.00	0.86	0.64
	ΔT	23	22	19	15	22	22	19	15	22	22	19	15	21	22	19	15	20	21	19	15	19	19	15	18	14
	kW	1.08	1.11	1.14	1.18	1.17	1.19	1.23	1.27	1.24	1.27	1.31	1.36	1.31	1.34	1.38	1.43	1.37	1.40	1.45	1.50	1.42	1.45	1.50	1.55	
	Amps	4.3	4.4	4.5	4.7	4.6	4.7	4.9	5.0	5.0	5.1	5.3	5.5	5.3	5.4	5.6	5.8	5.7	5.8	6.0	6.2	6.0	6.1	6.3	6.6	
	Hi PR	213	229	242	253	239	258	272	284	272	293	309	323	310	334	352	367	349	375	396	413	385	415	438	457	
	Lo PR	116	123	134	143	122	130	142	151	127	135	147	157	133	142	155	165	140	149	162	173	145	154	168	179	
	MBh	17.8	18.2	19.4	20.8	17.4	17.8	19.0	20.3	17.0	17.3	18.5	19.8	16.5	16.9	18.1	19.3	15.7	16.1	17.2	18.3	14.6	14.9	15.9	17.0	
	S/T	0.94	0.88	0.72	0.53	0.97	0.91	0.74	0.55	1.00	0.93	0.76	0.57	1.00	0.96	0.78	0.59	1.00	1.00	0.81	0.61	1.00	1.00	0.82	0.61	
	ΔT	24	23	20	16	24	23	20	16	24	23	20	16	24	24	20	16	23	23	20	16	21	21	19	15	
kW	1.07	1.10	1.13	1.17	1.16	1.18	1.22	1.26	1.23	1.26	1.30	1.35	1.30	1.33	1.37	1.42	1.36	1.39	1.43	1.48	1.40	1.44	1.48	1.54		
Amps	4.2	4.3	4.5	4.6	4.6	4.7	4.8	5.0	4.9	5.1	5.2	5.4	5.3	5.4	5.6	5.8	5.6	5.7	5.9	6.2	5.9	6.1	6.3	6.5		
Hi PR	211	227	240	250	237	255	269	281	269	290	306	319	307	330	349	364	345	372	392	409	381	411	433	452		
Lo PR	114	122	133	142	121	129	140	150	126	134	146	155	132	140	153	163	138	147	161	171	143	152	166	177		
MBh	16.9	17.3	18.4	19.7	16.5	16.9	18.0	19.3	16.1	16.5	17.6	18.8	15.7	16.1	17.2	18.3	14.9	15.3	16.3	17.4	13.8	14.1	15.1	16.1		
S/T	0.90	0.84	0.69	0.51	0.93	0.87	0.71	0.53	0.95	0.89	0.73	0.54	0.98	0.92	0.75	0.56	1.02	0.96	0.78	0.58	1.03	0.97	0.79	0.59		
ΔT	25	23	20	16	25	24	21	17	25	24	21	17	25	24	21	17	25	24	21	16	23	22	19	15		
kW	1.06	1.08	1.11	1.15	1.14	1.16	1.20	1.24	1.21	1.24	1.28	1.32	1.28	1.31	1.35	1.40	1.33	1.36	1.41	1.46	1.38	1.41	1.46	1.51		
Amps	4.1	4.2	4.4	4.5	4.5	4.6	4.7	4.9	4.8	5.0	5.1	5.3	5.2	5.3	5.5	5.7	5.5	5.6	5.8	6.0	5.8	6.0	6.2	6.4		
Hi PR	207	223	235	245	232	250	264	275	264	284	300	313	301	324	342	356	338	364	384	401	374	402	425	443		
Lo PR	112	119	130	139	118	126	138	147	123	131	143	152	129	138	150	160	136	144	157	168	140	149	163	173		

85	731	MBh	18.6	19.0	19.9	21.2	18.2	18.6	19.4	20.7	17.8	18.1	19.0	20.2	17.3	17.7	18.5	19.7	16.5	16.8	17.6	18.8	15.3	15.6	16.3	17.4
		S/T	1.00	0.99	0.90	0.73	1.00	1.00	0.93	0.75	1.00	1.00	0.95	0.77	1.00	1.00	0.98	0.80	1.00	1.00	0.83	1.00	1.00	0.83	1.00	0.84
	ΔT	23	24	22	19	23	23	20	16	22	23	20	16	22	22	23	20	16	21	21	18	19	15	11	11	
	kW	1.09	1.11	1.15	1.19	1.18	1.20	1.24	1.29	1.25	1.28	1.32	1.37	1.32	1.35	1.40	1.44	1.38	1.41	1.46	1.51	1.43	1.46	1.51	1.56	
	Amps	4.3	4.4	4.5	4.7	4.6	4.7	4.9	5.1	5.0	5.1	5.3	5.5	5.4	5.5	5.7	5.9	5.7	5.8	6.0	6.3	6.0	6.2	6.4	6.6	
	Hi PR	215	232	245	255	242	260	275	286	275	296	312	326	313	337	356	371	352	379	400	417	389	419	442	461	
	Lo PR	117	124	136	144	123	131	143	153	128	136	149	159	135	143	156	167	141	150	164	175	146	155	170	181	
	MBh	18.1	18.4	19.3	20.6	17.7	18.0	18.9	20.1	17.3	17.6	18.4	19.7	16.8	17.2	18.0	19.2	16.0	16.3	17.1	18.2	14.8	15.1	15.8	16.9	
	S/T	0.98	0.95	0.86	0.69	1.00	0.98	0.89	0.72	1.00	1.00	0.91	0.74	1.00	1.00	0.94	0.76	1.00	1.00	0.97	0.79	1.00	1.00	0.98	0.80	
	ΔT	26	25	24	21	26	26	24	21	25	25	24	21	24	25	24	21	23	24	24	21	21	22	22	19	
kW	1.08	1.11	1.14	1.18	1.17	1.19	1.23	1.27	1.24	1.27	1.31	1.36	1.31	1.34	1.38	1.43	1.37	1.40	1.45	1.50	1.42	1.45	1.50	1.55		
Amps	4.3	4.4	4.5	4.7	4.6	4.7	4.9	5.0	5.0	5.1	5.3	5.5	5.3	5.4	5.6	5.8	5.7	5.8	6.0	6.2	6.0	6.1	6.3	6.6		
Hi PR	213	229	242	253	239	258	272	284	272	293	309	323	310	334	352	367	349	375	396	413	385	415	438	457		
Lo PR	116	123	134	143	122	130	142	151	127	135	147	157	133	142	155	165	140	149	162	173	145	154	168	179		
MBh	17.2	17.5	18.4	19.6	16.8	17.1	17.9	19.1	16.4	16.7	17.5	18.7	16.0	16.3	17.1	18.2	15.2	15.5	16.2	17.3	14.1	14.3	15.0	16.0		
S/T	0.94	0.91	0.82	0.66	0.98	0.94	0.85	0.69	1.00	0.96	0.87	0.71	1.00	1.00	0.90	0.73	1.00	1.00	0.93	0.76	1.00	1.00	0.94	0.76		
ΔT	26.1	26	24	21	26	26	25	21	26	26	25	21	26	26	25	21	25	25	24	21	23	23	23	20		
kW	1.06	1.09	1.12	1.16	1.15	1.17	1.21	1.25	1.22	1.25	1.29	1.33	1.29	1.32	1.36	1.41	1.34	1.37	1.42	1.47	1.39	1.42	1.47	1.52		
Amps	4.2	4.3	4.4	4.6	4.5	4.6	4.8	4.9	4.9	5.0	5.2	5.4	5.2	5.3	5.5	5.7	5.6	5.7	5.9	6.1	5.9	6.0	6.2	6.5		
Hi PR	209	225	237	248	235	252	266	278	267	287	303	316	304	327	345	360	342	368	388	405	378	406	429	448		
Lo PR	113	121	132	140	120	127	139	148	124	132	144	154	131	139	152	162	137	146	159	169	142	151	164	175		

IDB: Entering Indoor Dry Bulb Temperature
 High and low pressures are measured at the liquid and suction service valves.

kW = Total system power
 Shaded area is ARI Rating Conditions
 Amps = outdoor unit amps (comp.+fan)

EXPANDED COOLING DATA — ASZ160241A* / CA*F3636*6A* + TXV / MBE1600** -1 HIGH STAGE

IDB	Airflow	Outdoor Ambient Temperature																								
		65°F				75°F				85°F				95°F				105°F				115°F				
		59	63	67	71	59	63	67	71	59	63	67	71	59	63	67	71	59	63	67	71	59	63	67	71	
70	984	MBh	23.5	24.4	26.7	-	23.0	23.8	26.1	-	22.4	23.2	25.5	-	21.9	22.7	24.8	-	20.8	21.5	23.6	-	19.3	20.0	21.9	-
		S/T	0.80	0.66	0.46	-	0.82	0.69	0.48	-	0.85	0.71	0.49	-	0.87	0.73	0.51	-	0.91	0.76	0.52	-	0.91	0.76	0.53	-
	ΔT	17	15	11	-	18	15	12	-	18	15	12	-	18	15	12	-	18	15	12	-	16	14	11	-	
	kW	1.56	1.60	1.65	-	1.68	1.72	1.78	-	1.79	1.83	1.90	-	1.89	1.93	2.00	-	1.97	2.02	2.09	-	2.04	2.09	2.16	-	
	Amps	6.0	6.1	6.3	-	6.5	6.6	6.8	-	7.0	7.2	7.4	-	7.5	7.7	7.9	-	8.0	8.2	8.5	-	8.5	8.7	9.0	-	
	Hi PR	223	240	253	-	250	269	284	-	284	306	323	-	324	349	368	-	365	392	414	-	403	433	458	-	
	Lo PR	111	118	129	-	117	125	136	-	122	130	142	-	128	136	149	-	134	143	156	-	139	148	161	-	
	MBh	22.8	23.7	25.9	-	22.3	23.1	25.3	-	21.8	22.6	24.7	-	21.2	22.0	24.1	-	20.2	20.9	22.9	-	18.7	19.4	21.2	-	
	S/T	0.76	0.63	0.44	-	0.79	0.66	0.46	-	0.81	0.67	0.47	-	0.83	0.70	0.48	-	0.86	0.72	0.50	-	0.87	0.73	0.50	-	
	ΔT	18	16	12	-	18	16	12	-	18	16	12	-	19	16	12	-	18	16	12	-	17	15	11	-	
kW	1.55	1.58	1.63	-	1.67	1.71	1.76	-	1.78	1.82	1.88	-	1.87	1.92	1.98	-	1.96	2.00	2.07	-	2.03	2.07	2.14	-		
Amps	5.9	6.1	6.3	-	6.4	6.6	6.8	-	7.0	7.1	7.4	-	7.4	7.6	7.9	-	7.9	8.1	8.4	-	8.4	8.6	8.9	-		
Hi PR	221	238	251	-	248	267	281	-	282	303	320	-	321	345	365	-	361	388	410	-	399	429	453	-		
Lo PR	110	117	128	-	116	124	135	-	121	128	140	-	127	135	147	-	133	141	154	-	137	146	160	-		
MBh	21.1	21.8	23.9	-	20.6	21.3	23.4	-	20.1	20.8	22.8	-	19.6	20.3	22.3	-	18.6	19.3	21.1	-	17.3	17.9	19.6	-		
S/T	0.73	0.61	0.42	-	0.76	0.63	0.44	-	0.78	0.65	0.45	-	0.80	0.67	0.46	-	0.83	0.70	0.48	-	0.84	0.70	0.49	-		
ΔT	19	16	12	-	19	16	12	-	19	16	12	-	19	16	12	-	19	16	12	-	17	15	11	-		
kW	1.51	1.54	1.59	-	1.63	1.67	1.72	-	1.73	1.77	1.83	-	1.83	1.87	1.93	-	1.91	1.95	2.01	-	1.97	2.02	2.09	-		
Amps	5.8	5.9	6.1	-	6.2	6.4	6.6	-	6.8	6.9	7.2	-	7.2	7.4	7.6	-	7.7	7.9	8.1	-	8.1	8.3	8.6	-		
Hi PR	214	230	243	-	240	259	273	-	273	294	310	-	311	335	354	-	350	377	398	-	387	416	440	-		
Lo PR	107	113	124	-	113	120	131	-	117	125	136	-	123	131	143	-	129	137	150	-	133	142	155	-		

75	984	MBh	23.9	24.6	26.7	28.6	23.4	24.1	26.0	27.9	22.8	23.5	25.4	27.3	22.2	22.9	24.8	26.6	21.1	21.8	23.6	25.3	19.6	20.2	21.8	23.4
		S/T	0.90	0.81	0.61	0.39	0.94	0.84	0.63	0.41	0.96	0.86	0.65	0.42	0.99	0.89	0.67	0.43	1.00	0.92	0.70	0.45	1.00	0.93	0.70	0.45
	ΔT	20	19	15	11	20	19	15	11	20	19	15	11	21	19	16	11	20	19	15	11	18	17	14	10	
	kW	1.57	1.61	1.66	1.72	1.70	1.74	1.79	1.85	1.81	1.85	1.91	1.98	1.91	1.95	2.02	2.08	1.99	2.03	2.10	2.18	2.06	2.11	2.18	2.26	
	Amps	6.0	6.2	6.4	6.6	6.5	6.7	6.9	7.2	7.1	7.3	7.5	7.8	7.6	7.8	8.0	8.3	8.1	8.3	8.5	8.9	8.5	8.7	9.0	9.4	
	Hi PR	225	242	256	267	253	272	287	300	287	309	327	341	327	352	372	388	368	396	418	436	407	438	462	482	
	Lo PR	112	119	130	139	119	126	138	147	123	131	143	152	129	138	150	160	136	144	157	168	140	149	163	173	
	MBh	23.2	23.9	25.9	27.8	22.7	23.4	25.3	27.1	22.1	22.8	24.7	26.5	21.6	22.2	24.1	25.8	20.5	21.1	22.9	24.5	19.0	19.6	21.2	22.7	
	S/T	0.86	0.77	0.58	0.38	0.89	0.80	0.61	0.39	0.92	0.82	0.62	0.40	0.95	0.85	0.64	0.41	0.98	0.88	0.67	0.43	0.99	0.89	0.67	0.43	
	ΔT	21	19	16	11	21	20	16	11	21	20	16	11	21	20	16	11	21	20	16	11	20	18	15	10	
kW	1.56	1.60	1.65	1.70	1.68	1.72	1.78	1.84	1.79	1.83	1.90	1.96	1.89	1.93	2.00	2.07	1.97	2.02	2.09	2.16	2.04	2.09	2.16	2.24		
Amps	6.0	6.1	6.3	6.6	6.5	6.6	6.8	7.1	7.0	7.2	7.4	7.7	7.5	7.7	7.9	8.2	8.0	8.2	8.5	8.8	8.5	8.7	9.0	9.3		
Hi PR	223	240	253	264	250	269	284	297	285	306	323	337	324	349	368	384	365	392	414	432	403	434	458	477		
Lo PR	111	118	129	137	117	125	136	145	122	130	142	151	128	136	149	158	134	143	156	166	139	148	161	172		
MBh	21.4	22.1	23.9	25.6	20.9	21.6	23.3	25.0	20.4	21.0	22.8	24.4	19.9	20.5	22.2	23.8	18.9	19.5	21.1	22.7	17.5	18.1	19.6	21.0		
S/T	0.83	0.74	0.56	0.36	0.86	0.77	0.58	0.38	0.88	0.79	0.60	0.39	0.91	0.82	0.62	0.40	0.95	0.85	0.64	0.41	0.96	0.85	0.65	0.42		
ΔT	21	20	16	11	22	20	16	11	22	20	16	11	22	20	16	11	22	20	16	11	20	19	15	10		
kW	1.52	1.56	1.61	1.66	1.64	1.68	1.73	1.79	1.75	1.79	1.85	1.91	1.84	1.88	1.95	2.01	1.92	1.97	2.03	2.10	1.99	2.04	2.10	2.18		
Amps	5.8	6.0	6.2	6.4	6.3	6.4	6.6	6.9	6.8	7.0	7.2	7.5	7.3	7.5	7.7	8.0	7.8	8.0	8.2	8.5	8.2	8.4	8.7	9.0		
Hi PR	216	233	246	256	243	261	276	288	276	297	314	327	314	338	357	373	354	381	402	419	391	421	444	463		
Lo PR	108	115	125	133	114	121	132	141	118	126	137	146	124	132	144	154	130	139	151	161	135	143	156	167		

IDB: Entering Indoor Dry Bulb Temperature kW = Total system power Shaded area is ACCA (TVA) conditions Amps = outdoor unit amps (comp.+fan)
 High and low pressures are measured at the liquid and suction service valves.

EXPANDED COOLING DATA — ASZ160241A* / CA*F3636*6A* + TXV / MBE1600** -1 HIGH STAGE (CONT.)

IDB	Airflow	Outdoor Ambient Temperature																								
		65°F				75°F				85°F				95°F				105°F				115°F				
		59	63	67	71	59	63	67	71	59	63	67	71	59	63	67	71	59	63	67	71	59	63	67	71	
80	984	MBh	24.3	24.9	26.6	28.4	23.8	24.3	26.0	27.7	23.2	23.7	25.3	27.1	22.6	23.1	24.7	26.4	21.5	22.0	23.5	25.1	19.9	20.4	21.8	23.3
		S/T	1.00	0.93	0.76	0.57	1.00	0.96	0.79	0.59	1.00	1.00	0.81	0.60	1.00	1.00	0.83	0.62	1.00	1.00	0.86	0.64	1.00	1.00	0.87	0.65
		ΔT	23	22	19	15	22	22	19	15	21	22	19	15	20	21	19	15	20	21	19	15	19	19	18	14
		kW	1.59	1.62	1.67	1.73	1.71	1.75	1.81	1.87	1.82	1.87	1.93	1.99	1.92	1.97	2.03	2.10	2.01	2.05	2.12	2.20	2.08	2.13	2.20	2.28
		Amps	6.1	6.2	6.4	6.7	6.6	6.7	7.0	7.2	7.1	7.3	7.6	7.9	7.6	7.8	8.1	8.4	8.1	8.3	8.6	8.9	8.6	8.8	9.1	9.5
	Hi PR	227	245	258	270	255	275	290	303	290	312	330	344	331	356	376	392	372	400	423	441	411	442	467	487	
	Lo PR	113	121	132	140	120	127	139	148	124	132	145	154	131	139	152	162	137	146	159	169	142	151	165	175	
	MBh	23.6	24.1	25.8	27.6	23.1	23.6	25.2	26.9	22.5	23.0	24.6	26.3	22.0	22.5	24.0	25.7	20.9	21.3	22.8	24.4	19.3	19.8	21.1	22.6	
	S/T	0.95	0.89	0.72	0.54	0.98	0.92	0.75	0.56	1.00	0.94	0.77	0.57	1.00	0.97	0.79	0.59	1.00	1.00	0.82	0.61	1.00	1.00	0.83	0.62	
	ΔT	24	23	20	16	24	23	20	16	24	23	20	16	23	23	20	16	22	22	20	16	20	21	18	15	
kW	1.57	1.61	1.66	1.72	1.70	1.74	1.79	1.85	1.81	1.85	1.91	1.98	1.91	1.95	2.02	2.08	1.99	2.03	2.10	2.18	2.06	2.11	2.18	2.26		
Amps	6.0	6.2	6.4	6.6	6.5	6.7	6.9	7.2	7.1	7.3	7.5	7.8	7.6	7.8	8.0	8.3	8.1	8.3	8.5	8.9	8.5	8.7	9.0	9.4		
Hi PR	225	242	256	267	253	272	287	300	287	309	327	341	327	352	372	388	368	396	419	436	407	438	462	482		
Lo PR	112	119	130	139	119	126	138	147	123	131	143	152	129	138	150	160	136	144	158	168	140	149	163	174		
MBh	21.8	22.3	23.8	25.5	21.3	21.8	23.3	24.9	20.8	21.3	22.7	24.3	20.3	20.7	22.2	23.7	19.3	19.7	21.0	22.5	17.9	18.2	19.5	20.8		
S/T	0.91	0.86	0.70	0.52	0.95	0.89	0.72	0.54	0.97	0.91	0.74	0.55	1.00	0.94	0.76	0.57	1.04	0.97	0.79	0.59	1.05	0.98	0.80	0.60		
ΔT	24	23	20	16	24	23	20	16	24	23	20	16	24	23	20	16	24	23	20	16	22	22	19	15		
kW	1.54	1.57	1.62	1.67	1.66	1.69	1.75	1.81	1.76	1.80	1.86	1.93	1.86	1.90	1.96	2.03	1.94	1.98	2.05	2.12	2.01	2.05	2.12	2.20		
Amps	5.9	6.0	6.2	6.4	6.3	6.5	6.7	7.0	6.9	7.1	7.3	7.6	7.4	7.5	7.8	8.1	7.8	8.0	8.3	8.6	8.3	8.5	8.8	9.1		
Hi PR	218	235	248	259	245	264	279	291	279	300	317	330	318	342	361	376	357	384	406	423	395	425	449	468		
Lo PR	109	116	126	135	115	122	134	142	120	127	139	148	126	134	146	155	132	140	153	163	136	145	158	168		

85	984	MBh	24.8	25.2	26.4	28.2	24.2	24.7	25.8	27.6	23.6	24.1	25.2	26.9	23.0	23.5	24.6	26.2	21.9	22.3	23.4	24.9	20.3	20.7	21.6	23.1
		S/T	1.00	1.00	0.91	0.74	1.00	1.00	0.94	0.76	1.00	1.00	0.96	0.78	1.00	1.00	0.99	0.81	1.00	1.00	1.00	0.84	1.00	1.00	1.00	0.84
		ΔT	23	24	22	19	23	23	23	20	22	22	23	20	22	22	23	20	20	21	22	19	19	19	20	18
		kW	1.60	1.64	1.69	1.74	1.73	1.77	1.82	1.89	1.84	1.88	1.94	2.01	1.94	1.98	2.05	2.12	2.02	2.07	2.14	2.21	2.10	2.14	2.22	2.30
		Amps	6.1	6.3	6.5	6.7	6.6	6.8	7.0	7.3	7.2	7.4	7.6	7.9	7.7	7.9	8.2	8.5	8.2	8.4	8.7	9.0	8.7	8.9	9.2	9.6
	Hi PR	230	247	261	272	258	277	293	306	293	316	333	348	334	359	379	396	376	404	427	445	415	447	472	492	
	Lo PR	114	122	133	142	121	129	140	150	126	134	146	155	132	140	153	163	138	147	161	171	143	152	166	177	
	MBh	24.0	24.5	25.7	27.4	23.5	23.9	25.1	26.8	22.9	23.4	24.5	26.1	22.4	22.8	23.9	25.5	21.2	21.7	22.7	24.2	19.7	20.1	21.0	22.4	
	S/T	0.99	0.96	0.86	0.70	1.00	0.99	0.90	0.73	1.00	1.00	0.92	0.74	1.00	1.00	0.95	0.77	1.00	1.00	0.98	0.80	1.00	1.00	0.99	0.80	
	ΔT	25	25	23	20	25	25	24	20	24	25	24	20	24	24	24	21	22	23	23	20	21	21	22	19	
kW	1.59	1.62	1.67	1.73	1.71	1.75	1.81	1.87	1.82	1.87	1.93	1.99	1.92	1.97	2.03	2.10	2.01	2.05	2.12	2.20	2.08	2.13	2.20	2.28		
Amps	6.1	6.2	6.4	6.7	6.6	6.7	7.0	7.2	7.1	7.3	7.6	7.9	7.6	7.8	8.1	8.4	8.1	8.3	8.6	8.9	8.6	8.8	9.1	9.5		
Hi PR	227	245	258	270	255	275	290	303	290	312	330	344	331	356	376	392	372	400	423	441	411	442	467	487		
Lo PR	113	121	132	140	120	127	139	148	124	132	145	154	131	139	152	162	137	146	159	169	142	151	165	175		
MBh	22.2	22.6	23.7	25.3	21.7	22.1	23.1	24.7	21.2	21.6	22.6	24.1	20.6	21.0	22.0	23.5	19.6	20.0	20.9	22.3	18.2	18.5	19.4	20.7		
S/T	0.96	0.92	0.83	0.68	0.99	0.96	0.86	0.70	1.00	0.98	0.89	0.72	1.00	1.00	0.91	0.74	1.00	1.00	0.95	0.77	1.00	1.00	0.96	0.78		
ΔT	25	25	24	21	26	25	24	21	25	25	24	21	25	25	24	21	24	24	24	21	22	22	22	19		
kW	1.55	1.58	1.63	1.69	1.67	1.71	1.76	1.82	1.78	1.82	1.88	1.94	1.87	1.92	1.98	2.05	1.95	2.00	2.07	2.14	2.02	2.07	2.14	2.22		
Amps	5.9	6.1	6.3	6.5	6.4	6.6	6.8	7.0	7.0	7.1	7.4	7.6	7.4	7.6	7.9	8.2	7.9	8.1	8.4	8.7	8.4	8.6	8.9	9.2		
Hi PR	221	237	251	262	248	266	281	293	282	303	320	334	321	345	364	380	361	388	410	428	399	429	453	472		
Lo PR	110	117	128	136	116	124	135	144	121	128	140	149	127	135	147	157	133	141	154	164	137	146	160	170		

IDB: Entering Indoor Dry Bulb Temperature
 High and low pressures are measured at the liquid and suction service valves.

kW = Total system power
 Shaded area is ARI Rating Conditions
 Amps = outdoor unit amps (comp.+fan)

EXPANDED COOLING DATA — AS2160361A* / CA*F3642*6A* + TXV / MBE1600** -1 LOW STAGE

IDB	Airflow	Outdoor Ambient Temperature																								
		65°F				75°F				85°F				95°F				105°F				115°F				
		59	63	67	71	59	63	67	71	59	63	67	71	59	63	67	71	59	63	67	71	59	63	67	71	
70	900	MBh	24.7	25.6	28.1	-	24.1	25.0	27.4	-	23.6	24.4	26.8	-	23.0	23.8	26.1	-	21.8	22.6	24.8	-	20.2	21.0	23.0	-
		S/T	0.75	0.62	0.43	-	0.77	0.65	0.45	-	0.79	0.66	0.46	-	0.82	0.68	0.47	-	0.85	0.71	0.49	-	0.86	0.72	0.50	-
		ΔT	19	16	12	-	19	17	13	-	19	17	13	-	19	17	13	-	19	16	12	-	18	15	12	-
		kW	1.44	1.48	1.52	-	1.56	1.59	1.64	-	1.66	1.69	1.75	-	1.74	1.78	1.84	-	1.82	1.86	1.92	-	1.88	1.93	1.99	-
		Amps	5.8	5.9	6.1	-	6.2	6.3	6.5	-	6.7	6.9	7.1	-	7.2	7.3	7.6	-	7.6	7.8	8.0	-	8.0	8.2	8.5	-
	800	Hi PR	207	223	236	-	233	250	265	-	265	285	301	-	302	324	343	-	339	365	385	-	375	403	426	-
		Lo PR	111	118	129	-	117	124	136	-	122	129	141	-	128	136	148	-	134	142	155	-	138	147	161	-
		MBh	24.0	24.9	27.3	-	23.4	24.3	26.6	-	22.9	23.7	26.0	-	22.3	23.1	25.4	-	21.2	22.0	24.1	-	19.6	20.4	22.3	-
		S/T	0.71	0.59	0.41	-	0.74	0.62	0.43	-	0.76	0.63	0.44	-	0.78	0.65	0.45	-	0.81	0.68	0.47	-	0.82	0.68	0.47	-
		ΔT	20	17	13	-	20	17	13	-	20	17	13	-	20	17	13	-	20	17	13	-	18	16	12	-
700	kW	1.43	1.46	1.51	-	1.54	1.58	1.63	-	1.64	1.68	1.73	-	1.73	1.77	1.83	-	1.80	1.84	1.91	-	1.87	1.91	1.97	-	
	Amps	5.7	5.8	6.0	-	6.2	6.3	6.5	-	6.7	6.8	7.0	-	7.1	7.3	7.5	-	7.5	7.7	8.0	-	8.0	8.1	8.4	-	
	Hi PR	205	221	233	-	230	248	262	-	262	282	298	-	299	321	339	-	336	361	382	-	371	399	422	-	
	Lo PR	110	117	127	-	116	123	135	-	120	128	140	-	126	135	147	-	133	141	154	-	137	146	159	-	
	MBh	22.2	23.0	25.2	-	21.6	22.4	24.6	-	21.1	21.9	24.0	-	20.6	21.4	23.4	-	19.6	20.3	22.2	-	18.1	18.8	20.6	-	

75	900	MBh	25.1	25.9	28.0	30.1	24.6	25.3	27.4	29.4	24.0	24.7	26.7	28.7	23.4	24.1	26.1	28.0	22.2	22.9	24.8	26.6	20.6	21.2	22.9	24.6
		S/T	0.85	0.76	0.57	0.37	0.88	0.79	0.60	0.38	0.90	0.81	0.61	0.39	0.93	0.83	0.63	0.41	0.97	0.86	0.65	0.42	0.97	0.87	0.66	0.42
		ΔT	22	20	16	11	22	20	17	11	22	20	17	12	22	20	17	12	22	20	17	11	20	19	15	11
		kW	1.46	1.49	1.53	1.59	1.57	1.60	1.66	1.71	1.67	1.71	1.76	1.82	1.76	1.80	1.86	1.92	1.83	1.88	1.94	2.00	1.90	1.94	2.01	2.08
		Amps	5.8	5.9	6.1	6.3	6.3	6.4	6.6	6.8	6.8	6.9	7.2	7.4	7.2	7.4	7.6	7.9	7.7	7.8	8.1	8.4	8.1	8.3	8.6	8.9
	800	Hi PR	210	226	238	248	235	253	267	279	267	288	304	317	305	328	346	361	343	369	389	406	379	407	430	449
		Lo PR	112	119	130	138	118	126	137	146	123	131	143	152	129	137	150	160	135	144	157	167	140	149	162	173
		MBh	24.4	25.1	27.2	29.2	23.8	24.5	26.6	28.5	23.3	24.0	25.9	27.8	22.7	23.4	25.3	27.2	21.6	22.2	24.0	25.8	20.0	20.6	22.3	23.9
		S/T	0.81	0.72	0.55	0.35	0.84	0.75	0.57	0.37	0.86	0.77	0.58	0.37	0.89	0.79	0.60	0.39	0.92	0.82	0.62	0.40	0.93	0.83	0.63	0.40
		ΔT	23	21	17	12	23	21	17	12	23	21	17	12	23	21	17	12	23	21	17	12	21	20	16	11
700	kW	1.44	1.48	1.52	1.57	1.56	1.59	1.64	1.70	1.66	1.69	1.75	1.81	1.74	1.78	1.84	1.90	1.82	1.86	1.92	1.99	1.88	1.93	1.99	2.06	
	Amps	5.8	5.9	6.1	6.3	6.2	6.3	6.5	6.8	6.7	6.9	7.1	7.3	7.2	7.3	7.6	7.8	7.6	7.8	8.0	8.3	8.0	8.2	8.5	8.8	
	Hi PR	207	223	236	246	233	251	265	276	265	285	301	314	302	325	343	357	339	365	386	402	375	403	426	444	
	Lo PR	111	118	129	137	117	125	136	145	122	129	141	150	128	136	148	158	134	142	156	166	139	147	161	171	
	MBh	22.5	23.2	25.1	26.9	22.0	22.7	24.5	26.3	21.5	22.1	23.9	25.7	21.0	21.6	23.4	25.1	19.9	20.5	22.2	23.8	18.4	19.0	20.6	22.1	

IDB: Entering Indoor Dry Bulb Temperature kW = Total system power Shaded area is ACCA (TVA) conditions Amps = outdoor unit amps (comp.+fan)
 High and low pressures are measured at the liquid and suction service valves.

EXPANDED COOLING DATA — ASZ160361A* / CA*F3642*6A* + TXV / MBE1600** -1 LOW STAGE (CONT.)

IDB	Airflow	Outdoor Ambient Temperature																								
		65°F				75°F				85°F				95°F				105°F				115°F				
		59	63	67	71	59	63	67	71	59	63	67	71	59	63	67	71	59	63	67	71	59	63	67	71	
80	900	MBh	25.6	26.1	27.9	29.9	25.0	25.5	27.3	29.2	24.4	24.9	26.6	28.5	23.8	24.3	26.0	27.8	22.6	23.1	24.7	26.4	20.9	21.4	22.9	24.4
		S/T	0.93	0.87	0.71	0.53	0.96	0.90	0.74	0.55	1.00	0.93	0.75	0.56	1.00	0.96	0.78	0.58	1.00	1.00	0.81	0.60	1.00	1.00	0.82	0.61
	ΔT	24	23	20	16	25	24	21	16	24	24	21	16	24	24	21	17	23	24	20	16	21	22	19	15	
	kW	1.47	1.50	1.55	1.60	1.58	1.62	1.67	1.73	1.68	1.72	1.78	1.84	1.77	1.81	1.87	1.94	1.85	1.89	1.95	2.02	1.92	1.96	2.02	2.09	
	Amps	5.9	6.0	6.2	6.4	6.3	6.5	6.7	6.9	6.8	7.0	7.2	7.5	7.3	7.5	7.7	8.0	7.7	7.9	8.2	8.5	8.2	8.4	8.6	9.0	
	Hi PR	212	228	241	251	238	256	270	282	270	291	307	320	308	331	350	365	346	372	393	410	382	412	435	453	
	Lo PR	113	120	131	140	119	127	139	148	124	132	144	154	130	139	151	161	137	145	159	169	141	150	164	175	
	MBh	24.8	25.4	27.1	29.0	24.3	24.8	26.5	28.3	23.7	24.2	25.9	27.6	23.1	23.6	25.2	27.0	22.0	22.4	24.0	25.6	20.3	20.8	22.2	23.7	
	S/T	0.89	0.83	0.68	0.51	0.92	0.86	0.70	0.52	0.94	0.88	0.72	0.54	0.97	0.91	0.74	0.56	1.00	0.95	0.77	0.58	1.00	0.96	0.78	0.58	
	ΔT	25	24	21	17	26	25	21	17	26	25	21	17	26	25	22	17	25	24	21	17	23	23	20	16	
kW	1.46	1.49	1.54	1.59	1.57	1.60	1.66	1.71	1.67	1.71	1.76	1.82	1.76	1.80	1.86	1.92	1.83	1.88	1.94	2.00	1.90	1.94	2.01	2.08		
Amps	5.8	5.9	6.1	6.3	6.3	6.4	6.6	6.8	6.8	6.9	7.2	7.4	7.2	7.4	7.6	7.9	7.7	7.8	8.1	8.4	8.1	8.3	8.6	8.9		
Hi PR	210	226	238	248	235	253	267	279	267	288	304	317	305	328	346	361	343	369	389	406	379	407	430	449		
Lo PR	112	119	130	138	118	126	137	146	123	131	143	152	129	137	150	160	135	144	157	167	140	149	162	173		
MBh	22.9	23.4	25.0	26.8	22.4	22.9	24.5	26.1	21.9	22.3	23.9	25.5	21.3	21.8	23.3	24.9	20.3	20.7	22.1	23.7	18.8	19.2	20.5	21.9		
S/T	0.86	0.80	0.65	0.49	0.89	0.83	0.68	0.51	0.91	0.85	0.69	0.52	0.94	0.88	0.72	0.54	0.97	0.91	0.74	0.56	0.98	0.92	0.75	0.56		
ΔT	26	25	21	17	26	25	22	17	26	25	22	17	26	25	22	18	26	25	22	17	24	23	20	16		
kW	1.42	1.45	1.50	1.55	1.53	1.56	1.62	1.67	1.63	1.66	1.72	1.78	1.71	1.75	1.81	1.87	1.79	1.83	1.89	1.95	1.85	1.89	1.96	2.02		
Amps	5.7	5.8	6.0	6.2	6.1	6.2	6.4	6.7	6.6	6.8	7.0	7.2	7.0	7.2	7.4	7.7	7.5	7.6	7.9	8.2	7.9	8.1	8.3	8.6		
Hi PR	203	219	231	241	228	245	259	270	259	279	295	307	295	318	336	350	332	358	378	394	367	395	417	435		
Lo PR	109	115	126	134	115	122	133	142	119	127	138	147	125	133	145	155	131	140	152	162	136	144	158	168		

85	900	MBh	26.0	26.5	27.8	29.7	25.4	25.9	27.2	29.0	24.8	25.3	26.5	28.3	24.2	24.7	25.9	27.6	23.0	23.5	24.6	26.2	21.3	21.7	22.8	24.3
		S/T	0.98	0.94	0.85	0.69	1.00	0.98	0.88	0.71	1.00	1.00	0.90	0.73	1.00	1.00	0.93	0.76	1.00	1.00	0.97	0.78	1.00	1.00	0.98	0.79
	ΔT	26	26	24	21	26	26	24	21	25	25	24	21	25	25	25	21	24	24	24	21	22	22	23	20	
	kW	1.48	1.51	1.56	1.61	1.60	1.63	1.68	1.74	1.70	1.74	1.79	1.85	1.79	1.83	1.89	1.95	1.87	1.91	1.97	2.04	1.93	1.98	2.04	2.11	
	Amps	5.9	6.1	6.2	6.5	6.4	6.5	6.7	7.0	6.9	7.1	7.3	7.5	7.3	7.5	7.8	8.0	7.8	8.0	8.2	8.5	8.2	8.4	8.7	9.0	
	Hi PR	214	230	243	253	240	258	273	284	273	294	310	323	311	334	353	368	350	376	397	414	386	416	439	458	
	Lo PR	114	121	133	141	121	128	140	149	125	133	146	155	132	140	153	163	138	147	160	171	143	152	166	177	
	MBh	25.3	25.8	27.0	28.8	24.7	25.2	26.4	28.1	24.1	24.6	25.7	27.5	23.5	24.0	25.1	26.8	22.3	22.8	23.8	25.4	20.7	21.1	22.1	23.6	
	S/T	0.93	0.90	0.81	0.66	0.96	0.93	0.84	0.68	0.99	0.95	0.86	0.70	1.00	0.98	0.89	0.72	1.00	1.00	0.92	0.75	1.00	1.00	0.93	0.75	
	ΔT	27	27	25	22	27	27	25	22	27	27	25	22	27	27	26	22	26	26	25	22	24	24	24	20	
kW	1.47	1.50	1.55	1.60	1.58	1.62	1.67	1.73	1.68	1.72	1.78	1.84	1.77	1.81	1.87	1.94	1.85	1.89	1.95	2.02	1.92	1.96	2.02	2.09		
Amps	5.9	6.0	6.2	6.4	6.3	6.5	6.7	6.9	6.8	7.0	7.2	7.5	7.3	7.5	7.7	8.0	7.7	7.9	8.2	8.5	8.2	8.4	8.6	9.0		
Hi PR	212	228	241	251	238	256	270	282	270	291	307	320	308	331	350	365	346	372	393	410	382	412	435	453		
Lo PR	113	120	131	140	119	127	139	148	124	132	144	154	130	139	151	161	137	145	159	169	141	150	164	175		
MBh	23.3	23.8	24.9	26.6	22.8	23.2	24.3	26.0	22.2	22.7	23.8	25.3	21.7	22.1	23.2	24.7	20.6	21.0	22.0	23.5	19.1	19.5	20.4	21.8		
S/T	0.90	0.87	0.78	0.63	0.93	0.90	0.81	0.66	0.95	0.92	0.83	0.67	0.98	0.95	0.86	0.70	1.00	0.99	0.89	0.72	1.00	0.99	0.90	0.73		
ΔT	27.5	27	26	22	28	27	26	22	28	27	26	22	28	28	26	23	27	27	26	22	25	25	24	21		
kW	1.43	1.46	1.51	1.56	1.54	1.58	1.63	1.68	1.64	1.68	1.73	1.79	1.73	1.77	1.83	1.89	1.80	1.84	1.90	1.97	1.87	1.91	1.97	2.04		
Amps	5.7	5.8	6.0	6.2	6.2	6.3	6.5	6.7	6.7	6.8	7.0	7.3	7.1	7.3	7.5	7.8	7.5	7.7	8.0	8.2	8.0	8.1	8.4	8.7		
Hi PR	205	221	233	243	230	248	262	273	262	282	298	311	298	321	339	354	336	361	382	398	371	399	422	440		
Lo PR	110	117	127	136	116	123	135	143	120	128	140	149	126	135	147	156	133	141	154	164	137	146	159	170		

IDB: Entering Indoor Dry Bulb Temperature
 High and low pressures are measured at the liquid and suction service valves.

kW = Total system power
 Shaded area is ARI Rating Conditions

Amps = outdoor unit amps (comp.+fan)

EXPANDED COOLING DATA — ASZ160361A* / CA*F3642*6A* + TXV / MBE1600** -1 HIGH STAGE

IDB	Airflow	Outdoor Ambient Temperature																							
		65°F				75°F				85°F				95°F				105°F				115°F			
		59	63	67	71	59	63	67	71	59	63	67	71	59	63	67	71	59	63	67	71	59	63	67	71
1294	MBh	33.9	35.1	38.5	-	33.1	34.3	37.6	-	32.3	33.5	36.7	-	31.5	32.7	35.8	-	30.0	31.1	34.0	-	27.8	28.8	31.5	-
	S/T	0.74	0.62	0.43	-	0.76	0.64	0.44	-	0.78	0.65	0.45	-	0.81	0.67	0.47	-	0.84	0.70	0.49	-	0.85	0.71	0.49	-
	ΔT	18	15	12	-	18	16	12	-	18	16	12	-	18	16	12	-	18	15	12	-	17	14	11	-
	kW	2.16	2.20	2.27	-	2.33	2.38	2.46	-	2.48	2.53	2.62	-	2.61	2.67	2.76	-	2.72	2.78	2.88	-	2.82	2.88	2.98	-
	Amps	8.3	8.5	8.8	-	9.0	9.2	9.5	-	9.7	10.0	10.3	-	10.4	10.7	11.0	-	11.1	11.3	11.7	-	11.7	12.0	12.4	-
	Hi PR	220	237	250	-	247	266	280	-	281	302	319	-	320	344	363	-	360	387	409	-	397	428	452	-
	Lo PR	108	114	125	-	114	121	132	-	118	126	137	-	124	132	144	-	130	138	151	-	135	143	156	-
	MBh	32.9	34.1	37.4	-	32.2	33.3	36.5	-	31.4	32.5	35.6	-	30.6	31.7	34.8	-	29.1	30.2	33.0	-	26.9	27.9	30.6	-
	S/T	0.70	0.59	0.41	-	0.73	0.61	0.42	-	0.75	0.62	0.43	-	0.77	0.64	0.45	-	0.80	0.67	0.46	-	0.81	0.67	0.47	-
	ΔT	18	16	12	-	19	16	12	-	19	16	12	-	19	16	12	-	19	16	12	-	17	15	11	-
70	kW	2.14	2.19	2.26	-	2.31	2.36	2.44	-	2.46	2.51	2.59	-	2.59	2.65	2.73	-	2.70	2.76	2.85	-	2.79	2.86	2.95	-
	Amps	8.2	8.4	8.7	-	8.9	9.1	9.4	-	9.7	9.9	10.2	-	10.3	10.6	10.9	-	11.0	11.2	11.6	-	11.6	11.9	12.3	-
	Hi PR	218	234	247	-	244	263	278	-	278	299	316	-	317	341	360	-	356	383	405	-	393	423	447	-
	Lo PR	107	113	124	-	113	120	131	-	117	124	136	-	123	131	143	-	129	137	150	-	133	142	155	-
	MBh	30.4	31.5	34.5	-	29.7	30.8	33.7	-	29.0	30.0	32.9	-	28.3	29.3	32.1	-	26.9	27.8	30.5	-	24.9	25.8	28.2	-
	S/T	0.68	0.57	0.39	-	0.70	0.59	0.41	-	0.72	0.60	0.42	-	0.74	0.62	0.43	-	0.77	0.64	0.45	-	0.78	0.65	0.45	-
	ΔT	19	16	12	-	19	16	13	-	19	16	13	-	19	17	13	-	19	16	12	-	18	15	12	-
	kW	2.09	2.13	2.20	-	2.25	2.30	2.37	-	2.39	2.45	2.53	-	2.52	2.58	2.66	-	2.63	2.69	2.78	-	2.72	2.78	2.88	-
	Amps	8.0	8.2	8.5	-	8.7	8.9	9.1	-	9.4	9.6	9.9	-	10.0	10.3	10.6	-	10.7	10.9	11.3	-	11.3	11.6	12.0	-
	Hi PR	211	227	240	-	237	255	269	-	270	290	306	-	307	330	349	-	345	372	393	-	382	411	434	-
Lo PR	103	110	120	-	109	116	127	-	113	121	132	-	119	127	138	-	125	133	145	-	129	137	150	-	

1294	MBh	34.5	35.5	38.4	41.2	33.7	34.7	37.5	40.3	32.9	33.8	36.6	39.3	32.1	33.0	35.7	38.4	30.5	31.4	34.0	36.4	28.2	29.1	31.5	33.8
	S/T	0.84	0.75	0.57	0.36	0.87	0.78	0.59	0.38	0.89	0.80	0.60	0.39	0.92	0.82	0.62	0.40	0.95	0.85	0.65	0.42	0.96	0.86	0.65	0.42
	ΔT	21	19	15	11	21	19	16	11	21	19	16	11	21	19	16	11	21	19	16	11	19	18	15	10
	kW	2.17	2.22	2.29	2.37	2.35	2.40	2.48	2.56	2.50	2.55	2.64	2.73	2.63	2.69	2.78	2.88	2.74	2.81	2.90	3.00	2.84	2.91	3.01	3.11
	Amps	8.4	8.6	8.9	9.2	9.1	9.3	9.6	9.9	9.8	10.1	10.4	10.8	10.5	10.8	11.1	11.5	11.2	11.4	11.8	12.3	11.8	12.1	12.5	13.0
	Hi PR	222	239	253	263	249	268	283	296	284	305	322	336	323	348	367	383	363	391	413	431	401	432	456	476
	Lo PR	109	116	126	134	115	122	133	142	119	127	139	148	125	133	146	155	131	140	153	163	136	145	158	168
	MBh	33.5	34.5	37.3	40.0	32.7	33.7	36.4	39.1	31.9	32.9	35.6	38.2	31.1	32.1	34.7	37.2	29.6	30.5	33.0	35.4	27.4	28.2	30.5	32.8
	S/T	0.80	0.71	0.54	0.35	0.83	0.74	0.56	0.36	0.85	0.76	0.57	0.37	0.88	0.78	0.59	0.38	0.91	0.81	0.62	0.40	0.92	0.82	0.62	0.40
	ΔT	21	20	16	11	22	20	16	11	22	20	16	11	22	20	16	11	22	20	16	11	20	18	15	10
75	kW	2.16	2.20	2.28	2.35	2.33	2.38	2.46	2.54	2.48	2.53	2.62	2.70	2.61	2.67	2.76	2.85	2.72	2.78	2.88	2.98	2.82	2.88	2.98	3.08
	Amps	8.3	8.5	8.8	9.1	9.0	9.2	9.5	9.8	9.7	10.0	10.3	10.7	10.4	10.7	11.0	11.4	11.1	11.3	11.7	12.2	11.7	12.0	12.4	12.9
	Hi PR	220	237	250	261	247	266	281	293	281	302	319	333	320	344	363	379	360	387	409	426	397	428	452	471
	Lo PR	108	115	125	133	114	121	132	141	118	126	137	146	124	132	144	154	130	138	151	161	135	143	156	166
	MBh	30.9	31.8	34.4	37.0	30.2	31.1	33.6	36.1	29.5	30.3	32.8	35.2	28.7	29.6	32.0	34.4	27.3	28.1	30.4	32.7	25.3	26.0	28.2	30.3
	S/T	0.77	0.69	0.52	0.34	0.80	0.71	0.54	0.35	0.82	0.73	0.55	0.36	0.84	0.76	0.57	0.37	0.88	0.78	0.59	0.38	0.88	0.79	0.60	0.39
	ΔT	22	20	16	11	22	20	17	11	22	20	17	11	22	20	17	12	22	20	16	11	20	19	15	11
	kW	2.10	2.15	2.22	2.29	2.27	2.32	2.39	2.47	2.41	2.47	2.55	2.64	2.54	2.60	2.69	2.78	2.65	2.71	2.80	2.90	2.75	2.81	2.90	3.00
	Amps	8.1	8.3	8.6	8.9	8.7	8.9	9.2	9.6	9.5	9.7	10.0	10.4	10.1	10.4	10.7	11.1	10.8	11.0	11.4	11.8	11.4	11.7	12.1	12.5
	Hi PR	213	230	243	253	239	258	272	284	272	293	309	323	310	334	352	368	349	376	397	414	386	415	438	457
Lo PR	104	111	121	129	110	117	128	136	115	122	133	142	120	128	140	149	126	134	147	156	131	139	152	161	

IDB: Entering Indoor Dry Bulb Temperature kW = Total system power Shaded area is ACCA (TVA) conditions Amps = outdoor unit amps (comp.+fan)
 High and low pressures are measured at the liquid and suction service valves.

EXPANDED COOLING DATA — AS2160361A* / CA*F3642*6A* + TXV / MBE1600** -1 HIGH STAGE (CONT.)

IDB	Airflow	Outdoor Ambient Temperature																								
		65°F				75°F				85°F				95°F				105°F				115°F				
		59	63	67	71	59	63	67	71	59	63	67	71	59	63	67	71	59	63	67	71	59	63	67	71	
80	1294	MBh	35.1	35.9	38.3	41.0	34.3	35.0	37.4	40.0	33.5	34.2	36.5	39.0	32.6	33.4	35.6	38.1	31.0	31.7	33.9	36.2	28.7	29.4	31.4	33.5
		S/T	0.92	0.86	0.70	0.52	0.95	0.89	0.73	0.54	1.00	0.92	0.74	0.56	1.00	0.94	0.77	0.57	1.00	1.00	0.80	0.60	1.00	1.00	0.80	0.60
	ΔT	23	22	19	15	23	22	19	15	24	22	19	15	23	22	19	16	22	21	19	15	20	21	18	14	
	kW	2.19	2.24	2.31	2.39	2.37	2.42	2.50	2.58	2.52	2.58	2.66	2.75	2.65	2.71	2.80	2.90	2.77	2.83	2.93	3.03	2.87	2.93	3.03	3.14	
	Amps	8.5	8.7	8.9	9.3	9.1	9.4	9.7	10.0	9.9	10.2	10.5	10.9	10.6	10.9	11.2	11.6	11.3	11.5	11.9	12.4	11.9	12.2	12.6	13.1	
	Hi PR	224	242	255	266	252	271	286	299	286	308	325	339	326	351	371	387	367	395	417	435	406	436	461	481	
	Lo PR	110	117	128	136	116	123	135	144	121	128	140	149	127	135	147	157	133	141	154	164	137	146	159	170	
	MBh	34.1	34.8	37.2	39.8	33.3	34.0	36.3	38.8	32.5	33.2	35.5	37.9	31.7	32.4	34.6	37.0	30.1	30.8	32.9	35.1	27.9	28.5	30.4	32.5	
	S/T	0.88	0.82	0.67	0.50	0.91	0.85	0.69	0.52	0.93	0.87	0.71	0.53	0.96	0.90	0.73	0.55	1.00	0.94	0.76	0.57	1.00	0.94	0.77	0.57	
	ΔT	24	23	20	16	24	23	20	16	24	23	20	16	24	23	20	16	24	23	20	16	22	21	19	15	
kW	2.18	2.22	2.29	2.37	2.35	2.40	2.48	2.56	2.50	2.55	2.64	2.73	2.63	2.69	2.78	2.88	2.74	2.81	2.90	3.00	2.84	2.91	3.01	3.11		
Amps	8.4	8.6	8.9	9.2	9.1	9.3	9.6	9.9	9.8	10.1	10.4	10.8	10.5	10.8	11.1	11.5	11.2	11.4	11.8	12.3	11.8	12.1	12.5	13.0		
Hi PR	222	239	253	263	249	268	283	296	284	305	322	336	323	348	367	383	363	391	413	431	401	432	456	476		
Lo PR	109	116	126	134	115	122	133	142	119	127	139	148	125	133	146	155	131	140	153	163	136	145	158	168		
MBh	31.4	32.1	34.3	36.7	30.7	31.4	33.5	35.8	30.0	30.6	32.7	35.0	29.3	29.9	31.9	34.1	27.8	28.4	30.3	32.4	25.7	26.3	28.1	30.0		
S/T	0.84	0.79	0.64	0.48	0.88	0.82	0.67	0.50	0.90	0.84	0.69	0.51	0.93	0.87	0.71	0.53	0.96	0.90	0.73	0.55	0.97	0.91	0.74	0.55		
ΔT	24	23	20	16	25	24	20	16	25	24	20	16	25	24	21	16	24	23	20	16	23	22	19	15		
kW	2.12	2.17	2.24	2.31	2.29	2.34	2.41	2.50	2.44	2.49	2.57	2.66	2.56	2.62	2.71	2.80	2.67	2.74	2.83	2.92	2.77	2.83	2.93	3.03		
Amps	8.2	8.4	8.6	8.9	8.8	9.0	9.3	9.7	9.6	9.8	10.1	10.5	10.2	10.5	10.8	11.2	10.9	11.1	11.5	11.9	11.5	11.8	12.2	12.6		
Hi PR	216	232	245	255	242	260	275	287	275	296	313	326	313	337	356	371	352	379	401	418	389	419	443	462		
Lo PR	105	112	122	130	111	119	129	138	116	123	134	143	122	129	141	150	127	136	148	158	132	140	153	163		

85	1294	MBh	35.7	36.4	38.1	40.7	34.9	35.6	37.2	39.7	34.0	34.7	36.3	38.8	33.2	33.9	35.5	37.8	31.6	32.2	33.7	35.9	29.2	29.8	31.2	33.3
		S/T	0.96	0.93	0.84	0.68	1.00	0.96	0.87	0.70	1.00	0.99	0.89	0.72	1.00	1.00	0.92	0.75	1.00	1.00	0.95	0.77	1.00	1.00	0.96	0.78
	ΔT	24	24	23	20	25	24	23	20	24	24	23	20	24	24	23	20	22	23	23	20	21	21	21	18	
	kW	2.21	2.26	2.33	2.41	2.39	2.44	2.52	2.60	2.54	2.60	2.68	2.77	2.68	2.74	2.83	2.93	2.79	2.86	2.95	3.05	2.89	2.96	3.06	3.17	
	Amps	8.5	8.7	9.0	9.4	9.2	9.4	9.7	10.1	10.0	10.3	10.6	11.0	10.7	11.0	11.3	11.7	11.4	11.7	12.0	12.5	12.0	12.3	12.8	13.2	
	Hi PR	227	244	258	269	254	274	289	301	289	311	329	343	329	355	374	391	371	399	421	439	410	441	465	485	
	Lo PR	111	118	129	137	117	125	136	145	122	130	141	151	128	136	149	158	134	143	156	166	139	148	161	172	
	MBh	34.7	35.3	37.0	39.5	33.9	34.5	36.1	38.6	33.1	33.7	35.3	37.6	32.2	32.9	34.4	36.7	30.6	31.2	32.7	34.9	28.4	28.9	30.3	32.3	
	S/T	0.92	0.89	0.80	0.65	0.95	0.92	0.83	0.67	0.98	0.94	0.85	0.69	1.00	0.97	0.88	0.71	1.00	1.00	0.91	0.74	1.00	1.00	0.92	0.74	
	ΔT	25	25	24	20	26	25	24	21	26	25	24	21	26	26	24	21	24	25	24	21	23	23	22	19	
kW	2.19	2.24	2.31	2.39	2.37	2.42	2.50	2.58	2.52	2.58	2.66	2.75	2.65	2.71	2.80	2.90	2.77	2.83	2.93	3.03	2.87	2.93	3.03	3.14		
Amps	8.5	8.7	8.9	9.3	9.1	9.4	9.7	10.0	9.9	10.2	10.5	10.9	10.6	10.9	11.2	11.6	11.3	11.5	11.9	12.4	11.9	12.2	12.6	13.1		
Hi PR	224	242	255	266	252	271	286	299	286	308	325	339	326	351	371	387	367	395	417	435	406	436	461	481		
Lo PR	110	117	128	136	116	123	135	144	121	128	140	149	127	135	147	157	133	141	154	164	137	146	159	170		
MBh	32.0	32.6	34.2	36.4	31.3	31.9	33.4	35.6	30.5	31.1	32.6	34.7	29.8	30.3	31.8	33.9	28.3	28.8	30.2	32.2	26.2	26.7	28.0	29.8		
S/T	0.89	0.85	0.77	0.63	0.92	0.89	0.80	0.65	0.94	0.91	0.82	0.66	0.97	0.94	0.85	0.69	1.00	0.97	0.88	0.71	1.00	0.98	0.89	0.72		
ΔT	26	25	24	21	26	26	24	21	26	26	24	21	26	26	25	21	26	26	24	21	24	24	23	20		
kW	2.14	2.19	2.26	2.33	2.31	2.36	2.43	2.52	2.46	2.51	2.59	2.68	2.59	2.64	2.73	2.83	2.70	2.76	2.85	2.95	2.79	2.86	2.95	3.06		
Amps	8.2	8.4	8.7	9.0	8.9	9.1	9.4	9.7	9.7	9.9	10.2	10.6	10.3	10.6	10.9	11.3	11.0	11.2	11.6	12.0	11.6	11.9	12.3	12.8		
Hi PR	218	234	247	258	244	263	278	290	278	299	316	329	316	341	360	375	356	383	405	422	393	423	447	466		
Lo PR	107	113	124	132	113	120	131	139	117	124	136	145	123	131	143	152	129	137	150	159	133	142	155	165		

IDB: Entering Indoor Dry Bulb Temperature
 High and low pressures are measured at the liquid and suction service valves.

kW = Total system power
 Shaded area is ARI Rating Conditions
 Amps = outdoor unit amps (comp.+fan)

EXPANDED COOLING DATA — ASZ160481A* / CA*F4860*6A* + TXV / MBE2000** -1 Low Stage

IDB	Airflow	Outdoor Ambient Temperature																							
		65°F				75°F				85°F				95°F				105°F				115°F			
		59	63	67	71	59	63	67	71	59	63	67	71	59	63	67	71	59	63	67	71	59	63	67	71
70	MBh	33.7	35.0	38.3	-	33.0	34.2	37.4	-	32.2	33.3	36.5	-	31.4	32.5	35.6	-	29.8	30.9	33.9	-	27.6	28.6	31.4	-
	S/T	0.74	0.62	0.43	-	0.77	0.64	0.45	-	0.79	0.66	0.46	-	0.81	0.68	0.47	-	0.85	0.71	0.49	-	0.85	0.71	0.49	-
	ΔT	19	16	13	-	19	17	13	-	19	17	13	-	19	17	13	-	19	17	13	-	18	15	12	-
	KW	1.96	2.00	2.07	-	2.12	2.16	2.23	-	2.25	2.30	2.38	-	2.37	2.43	2.51	-	2.48	2.53	2.62	-	2.57	2.62	2.71	-
	Amps	7.6	7.8	8.0	-	8.2	8.4	8.7	-	8.9	9.1	9.4	-	9.5	9.7	10.1	-	10.1	10.4	10.7	-	10.7	11.0	11.3	-
	Hi PR	205	220	233	-	230	247	261	-	261	281	297	-	297	320	338	-	335	360	380	-	370	398	420	-
	Lo PR	109	116	126	-	115	122	134	-	120	127	139	-	126	134	146	-	132	140	153	-	136	145	158	-
	MBh	32.8	34.0	37.2	-	32.0	33.2	36.3	-	31.2	32.4	35.5	-	30.5	31.6	34.6	-	28.9	30.0	32.9	-	26.8	27.8	30.4	-
	S/T	0.71	0.59	0.41	-	0.73	0.61	0.42	-	0.75	0.63	0.44	-	0.78	0.65	0.45	-	0.81	0.67	0.47	-	0.81	0.68	0.47	-
	ΔT	20	17	13	-	20	17	13	-	20	17	13	-	20	18	13	-	20	17	13	-	19	16	12	-
941	KW	1.95	1.99	2.05	-	2.10	2.15	2.22	-	2.23	2.28	2.36	-	2.35	2.41	2.49	-	2.46	2.51	2.60	-	2.54	2.60	2.69	-
	Amps	7.5	7.7	8.0	-	8.1	8.3	8.6	-	8.8	9.0	9.3	-	9.4	9.7	10.0	-	10.0	10.3	10.6	-	10.6	10.9	11.2	-
	Hi PR	203	218	230	-	227	245	258	-	259	278	294	-	294	317	335	-	331	356	376	-	366	394	416	-
	Lo PR	108	115	125	-	114	121	132	-	118	126	137	-	124	132	144	-	130	139	151	-	135	143	156	-
	MBh	30.2	31.3	34.3	-	29.5	30.6	33.5	-	28.8	29.9	32.7	-	28.1	29.1	31.9	-	26.7	27.7	30.3	-	24.7	25.7	28.1	-
	S/T	0.68	0.57	0.40	-	0.71	0.59	0.41	-	0.73	0.61	0.42	-	0.75	0.63	0.43	-	0.78	0.65	0.45	-	0.78	0.65	0.45	-
	ΔT	20	17	13	-	20	18	13	-	20	18	13	-	21	18	14	-	20	18	13	-	19	16	12	-
	KW	1.90	1.94	2.00	-	2.05	2.09	2.16	-	2.18	2.23	2.30	-	2.29	2.35	2.42	-	2.39	2.45	2.53	-	2.48	2.53	2.62	-
	Amps	7.3	7.5	7.8	-	7.9	8.1	8.4	-	8.6	8.8	9.1	-	9.2	9.4	9.7	-	9.8	10.0	10.3	-	10.3	10.6	10.9	-
	Hi PR	197	211	223	-	221	237	251	-	251	270	285	-	286	307	325	-	321	346	365	-	355	382	403	-
Lo PR	105	111	121	-	110	117	128	-	115	122	133	-	121	128	140	-	126	134	147	-	131	139	152	-	

75	MBh	34.3	35.3	38.2	41.0	33.5	34.5	37.3	40.1	32.7	33.7	36.5	39.1	31.9	32.9	35.6	38.2	30.3	31.2	33.8	36.3	28.1	28.9	31.3	33.6
	S/T	0.84	0.75	0.57	0.37	0.87	0.78	0.59	0.38	0.90	0.80	0.61	0.39	0.93	0.83	0.63	0.40	0.96	0.86	0.65	0.42	0.97	0.87	0.66	0.42
	ΔT	22	20	17	11	22	21	17	12	22	21	17	12	22	21	17	12	22	20	17	12	21	19	16	11
	KW	1.98	2.02	2.09	2.16	2.13	2.18	2.25	2.33	2.27	2.32	2.40	2.48	2.39	2.45	2.53	2.62	2.50	2.56	2.64	2.73	2.59	2.65	2.74	2.83
	Amps	7.7	7.9	8.1	8.4	8.3	8.5	8.8	9.1	9.0	9.2	9.5	9.9	9.6	9.8	10.2	10.5	10.2	10.5	10.8	11.2	10.8	11.1	11.4	11.9
	Hi PR	207	222	235	245	232	250	264	275	264	284	300	313	300	323	341	356	338	364	384	401	373	402	424	443
	Lo PR	110	117	128	136	116	124	135	144	121	128	140	149	127	135	147	157	133	141	154	164	137	146	160	170
	MBh	33.3	34.3	37.1	39.8	32.5	33.5	36.3	38.9	31.8	32.7	35.4	38.0	31.0	31.9	34.5	37.1	29.4	30.3	32.8	35.2	27.3	28.1	30.4	32.6
	S/T	0.80	0.72	0.54	0.35	0.83	0.75	0.56	0.36	0.86	0.77	0.58	0.37	0.88	0.79	0.60	0.38	0.92	0.82	0.62	0.40	0.92	0.83	0.63	0.40
	ΔT	23	21	17	12	23	21	18	12	23	21	18	12	23	22	18	12	23	21	17	12	22	20	16	11
941	KW	1.96	2.00	2.07	2.14	2.12	2.16	2.23	2.31	2.25	2.30	2.38	2.46	2.37	2.43	2.51	2.60	2.48	2.53	2.62	2.71	2.57	2.63	2.71	2.81
	Amps	7.6	7.8	8.0	8.3	8.2	8.4	8.7	9.0	8.9	9.1	9.4	9.8	9.5	9.7	10.1	10.4	10.1	10.4	10.7	11.1	10.7	11.0	11.3	11.8
	Hi PR	205	220	233	243	230	247	261	272	261	281	297	310	297	320	338	353	335	360	380	397	370	398	420	438
	Lo PR	109	116	126	135	115	122	134	142	120	127	139	148	126	134	146	155	132	140	153	163	136	145	158	168
	MBh	30.7	31.7	34.3	36.8	30.0	30.9	33.5	35.9	29.3	30.2	32.7	35.1	28.6	29.4	31.9	34.2	27.2	28.0	30.3	32.5	25.2	25.9	28.0	30.1
	S/T	0.78	0.69	0.53	0.34	0.80	0.72	0.54	0.35	0.82	0.74	0.56	0.36	0.85	0.76	0.58	0.37	0.88	0.79	0.60	0.38	0.89	0.80	0.60	0.39
	ΔT	23	21	18	12	24	22	18	12	24	22	18	12	24	22	18	12	23	22	18	12	22	20	17	11
	KW	1.91	1.95	2.02	2.08	2.06	2.11	2.18	2.25	2.20	2.25	2.32	2.40	2.31	2.37	2.45	2.53	2.41	2.47	2.55	2.64	2.50	2.56	2.64	2.74
	Amps	7.4	7.6	7.8	8.1	8.0	8.2	8.4	8.8	8.7	8.9	9.2	9.5	9.3	9.5	9.8	10.2	9.8	10.1	10.4	10.8	10.4	10.7	11.0	11.4
	Hi PR	199	214	226	235	223	240	253	264	253	273	288	300	289	311	328	342	325	349	369	385	359	386	408	425
Lo PR	106	112	123	131	112	119	130	138	116	123	135	143	122	130	141	151	128	136	148	158	132	140	153	163	

IDB: Entering Indoor Dry Bulb Temperature kW = Total system power Shaded area is ACCA (TVA) conditions Amps = outdoor unit amps (comp.+fan)
 High and low pressures are measured at the liquid and suction service valves.

EXPANDED COOLING DATA — ASZ160481A* / CA*F4860*6A* + TXV / MBE2000** -1 Low Stage (CONT.)

IDB	Airflow	Outdoor Ambient Temperature																									
		65°F				75°F				85°F				95°F				105°F				115°F					
		59	63	67	71	59	63	67	71	59	63	67	71	59	63	67	71	59	63	67	71	59	63	67	71		
80	1209	MBh	34.9	35.7	38.1	40.8	34.1	34.9	37.2	39.8	33.3	34.0	36.3	38.9	32.5	33.2	35.5	37.9	30.9	31.5	33.7	36.0	28.6	29.2	31.2	33.4	
		S/T	0.93	0.87	0.71	0.53	1.00	0.96	0.90	0.73	0.55	1.00	0.92	0.75	0.56	1.00	0.95	0.78	0.58	1.00	1.00	0.80	0.60	1.00	1.00	0.81	0.61
		ΔT	25	24	20	16	25	24	21	17	25	24	21	17	25	24	21	17	23	24	21	16	22	22	19	15	
		kW	1.99	2.04	2.10	2.17	2.15	2.20	2.27	2.35	2.29	2.34	2.42	2.50	2.42	2.47	2.55	2.64	2.52	2.58	2.67	2.76	2.61	2.67	2.76	2.86	
		Amps	7.7	7.9	8.2	8.5	8.4	8.6	8.8	9.2	9.1	9.3	9.6	10.0	9.7	9.9	10.3	10.6	10.3	10.6	10.9	11.3	10.9	11.2	11.6	12.0	
		Hi PR	209	225	237	247	234	252	266	278	266	287	303	316	303	327	345	360	341	367	388	405	377	406	429	447	
	Lo PR	111	118	129	137	117	125	136	145	122	130	142	151	128	136	149	158	134	143	156	166	139	148	161	172		
	MBh	33.9	34.6	37.0	39.6	33.1	33.8	36.2	38.6	32.3	33.0	35.3	37.7	31.5	32.2	34.4	36.8	30.0	30.6	32.7	35.0	27.8	28.4	30.3	32.4		
	S/T	0.88	0.83	0.67	0.50	0.91	0.86	0.70	0.52	0.94	0.88	0.72	0.54	0.97	0.91	0.74	0.55	1.00	0.94	0.77	0.57	1.00	0.95	0.77	0.58		
	ΔT	26	25	21	17	26	25	22	17	26	25	22	17	26	25	22	17	26	25	21	17	24	23	20	16		
	kW	1.98	2.02	2.09	2.16	2.13	2.18	2.25	2.33	2.27	2.32	2.40	2.48	2.40	2.45	2.53	2.62	2.50	2.56	2.64	2.73	2.59	2.65	2.74	2.83		
	Amps	7.7	7.9	8.1	8.4	8.3	8.5	8.8	9.1	9.0	9.2	9.5	9.9	9.6	9.8	10.2	10.5	10.2	10.5	10.8	11.2	10.8	11.1	11.4	11.9		
Hi PR	207	222	235	245	232	250	264	275	264	284	300	313	300	323	341	356	338	364	384	401	373	402	424	443			
Lo PR	110	117	128	136	116	124	135	144	121	128	140	149	127	135	147	157	133	141	154	164	137	146	160	170			
MBh	31.3	32.0	34.2	36.5	30.6	31.2	33.4	35.7	29.8	30.5	32.6	34.8	29.1	29.7	31.8	34.0	27.7	28.3	30.2	32.3	25.6	26.2	28.0	29.9			
S/T	0.85	0.80	0.65	0.49	0.88	0.83	0.67	0.50	0.90	0.85	0.69	0.52	0.93	0.88	0.71	0.53	0.97	0.91	0.74	0.55	0.98	0.92	0.75	0.56			
ΔT	26	25	22	17	26	25	22	18	26	25	22	18	27	25	22	18	26	25	22	17	24	23	20	16			
kW	1.93	1.97	2.03	2.10	2.08	2.13	2.20	2.27	2.22	2.26	2.34	2.42	2.33	2.39	2.47	2.55	2.43	2.49	2.57	2.66	2.52	2.58	2.67	2.76			
Amps	7.5	7.6	7.9	8.2	8.1	8.3	8.5	8.8	8.8	9.0	9.3	9.6	9.3	9.6	9.9	10.3	9.9	10.2	10.5	10.9	10.5	10.8	11.1	11.6			
Hi PR	201	216	228	238	225	242	256	267	256	275	291	303	291	314	331	345	328	353	373	389	362	390	412	429			
Lo PR	107	113	124	132	113	120	131	139	117	125	136	145	123	131	143	152	129	137	150	159	133	142	155	165			
85	1209	MBh	35.5	36.2	37.9	40.5	34.7	35.4	37.0	39.5	33.9	34.5	36.2	38.6	33.1	33.7	35.3	37.6	31.4	32.0	33.5	35.8	29.1	29.6	31.1	33.1	
		S/T	0.97	0.94	0.85	0.69	1.00	0.97	0.88	0.71	1.00	1.00	0.90	0.73	1.00	1.00	0.93	0.75	1.00	1.00	0.96	0.78	1.00	1.00	0.97	0.79	
		ΔT	26	26	24	21	26	26	25	21	26	26	25	21	25	26	25	22	24	24	25	21	22	23	23	20	
		kW	2.01	2.05	2.12	2.19	2.17	2.22	2.29	2.37	2.31	2.36	2.44	2.53	2.44	2.49	2.58	2.66	2.54	2.60	2.69	2.78	2.63	2.69	2.79	2.88	
		Amps	7.8	8.0	8.3	8.6	8.4	8.6	8.9	9.2	9.2	9.4	9.7	10.0	9.8	10.0	10.3	10.7	10.4	10.7	11.0	11.4	11.0	11.3	11.7	12.1	
		Hi PR	211	227	240	250	237	255	269	280	269	290	306	319	307	330	348	363	345	371	392	409	381	410	433	452	
	Lo PR	112	119	130	139	119	126	138	147	123	131	143	152	129	138	150	160	136	144	157	168	140	149	163	173		
	MBh	34.5	35.2	36.8	39.3	33.7	34.3	36.0	38.4	32.9	33.5	35.1	37.5	32.1	32.7	34.3	36.5	30.5	31.1	32.5	34.7	28.2	28.8	30.1	32.2		
	S/T	0.93	0.89	0.81	0.65	0.96	0.93	0.84	0.68	0.98	0.95	0.86	0.69	1.00	0.98	0.88	0.72	1.00	1.00	0.92	0.74	1.00	1.00	0.93	0.75		
	ΔT	27	27	25	22	28	27	26	22	28	27	26	22	27	27	26	22	26	27	26	22	24	25	24	21		
	kW	1.99	2.04	2.10	2.17	2.15	2.20	2.27	2.35	2.29	2.34	2.42	2.50	2.42	2.47	2.55	2.64	2.52	2.58	2.67	2.76	2.61	2.67	2.76	2.86		
	Amps	7.7	7.9	8.2	8.5	8.4	8.6	8.8	9.2	9.1	9.3	9.6	10.0	9.7	9.9	10.3	10.6	10.3	10.6	10.9	11.3	10.9	11.2	11.6	12.0		
Hi PR	209	225	237	247	234	252	266	278	266	287	303	316	303	327	345	360	341	367	388	405	377	406	429	447			
Lo PR	111	118	129	137	117	125	136	145	122	130	142	151	128	136	149	158	134	143	156	166	139	148	161	172			
MBh	31.8	32.5	34.0	36.3	31.1	31.7	33.2	35.4	30.4	30.9	32.4	34.6	29.6	30.2	31.6	33.7	28.1	28.7	30.0	32.0	26.1	26.6	27.8	29.7			
S/T	0.89	0.86	0.78	0.63	0.92	0.89	0.81	0.65	0.95	0.92	0.83	0.67	0.98	0.94	0.85	0.69	1.00	0.98	0.88	0.72	1.00	0.99	0.89	0.72			
ΔT	27.8	27	26	22	28	28	26	23	28	28	26	23	28	28	26	23	28	27	26	22	25	26	24	21			
kW	1.94	1.99	2.05	2.12	2.10	2.14	2.22	2.29	2.23	2.28	2.36	2.44	2.35	2.41	2.49	2.57	2.46	2.51	2.60	2.69	2.54	2.60	2.69	2.78			
Amps	7.5	7.7	8.0	8.3	8.1	8.3	8.6	8.9	8.8	9.0	9.3	9.7	9.4	9.7	10.0	10.3	10.0	10.3	10.6	11.0	10.6	10.9	11.2	11.7			
Hi PR	203	218	230	240	227	245	258	269	258	278	294	306	294	317	335	349	331	356	376	393	366	394	416	434			
Lo PR	108	115	125	133	114	121	132	141	118	126	137	146	124	132	144	154	130	139	151	161	135	143	156	167			

IDB: Entering Indoor Dry Bulb Temperature
 High and low pressures are measured at the liquid and suction service valves.
 kW = Total system power
 Shaded area is ARI Rating Conditions
 Amps = outdoor unit amps (comp.+fan)

EXPANDED COOLING DATA — ASZ160481A* / CA*F4860*6A* + TXV / MBE2000** -1 HIGH STAGE

IDB	Airflow	Outdoor Ambient Temperature																							
		65°F				75°F				85°F				95°F				105°F				115°F			
		59	63	67	71	59	63	67	71	59	63	67	71	59	63	67	71	59	63	67	71	59	63	67	71
70	MBh	46.5	48.2	52.9	-	45.5	47.1	51.6	-	44.4	46.0	50.4	-	43.3	44.9	49.2	-	41.1	42.6	46.7	-	38.1	39.5	43.3	-
	S/T	0.76	0.63	0.44	-	0.79	0.66	0.45	-	0.81	0.67	0.47	-	0.83	0.70	0.48	-	0.86	0.72	0.50	-	0.87	0.73	0.50	-
	ΔT	19	16	12	-	19	16	12	-	19	16	12	-	19	16	12	-	19	16	12	-	18	15	11	-
	kW	2.82	2.88	2.98	-	3.04	3.11	3.21	-	3.24	3.31	3.42	-	3.41	3.48	3.60	-	3.55	3.63	3.75	-	3.68	3.76	3.89	-
	Amps	5.8	6.0	6.4	-	6.6	6.9	7.3	-	7.6	7.9	8.3	-	8.5	8.8	9.3	-	9.3	9.7	10.2	-	10.2	10.5	11.1	-
	Hi PR	212	228	241	-	238	256	270	-	270	291	307	-	308	331	350	-	346	373	393	-	382	412	435	-
	Lo PR	107	114	124	-	113	120	131	-	117	125	136	-	123	131	143	-	129	137	150	-	133	142	155	-
	MBh	45.2	46.8	51.3	-	44.1	45.7	50.1	-	43.1	44.7	48.9	-	42.0	43.6	47.7	-	39.9	41.4	45.4	-	37.0	38.3	42.0	-
	S/T	0.72	0.60	0.42	-	0.75	0.63	0.43	-	0.77	0.64	0.44	-	0.79	0.66	0.46	-	0.82	0.69	0.48	-	0.83	0.69	0.48	-
	ΔT	19	17	13	-	20	17	13	-	20	17	13	-	20	17	13	-	20	17	13	-	18	16	12	-
kW	2.80	2.86	2.95	-	3.02	3.08	3.18	-	3.21	3.28	3.39	-	3.38	3.45	3.57	-	3.52	3.60	3.72	-	3.65	3.73	3.86	-	
Amps	5.7	5.9	6.3	-	6.5	6.8	7.2	-	7.5	7.8	8.2	-	8.4	8.7	9.1	-	9.2	9.5	10.0	-	10.0	10.4	10.9	-	
Hi PR	210	226	238	-	235	253	267	-	267	288	304	-	305	328	346	-	343	369	389	-	379	408	430	-	
Lo PR	106	112	123	-	112	119	130	-	116	123	135	-	122	130	142	-	128	136	148	-	132	141	153	-	
MBh	41.7	43.2	47.4	-	40.7	42.2	46.3	-	39.8	41.2	45.2	-	38.8	40.2	44.1	-	36.9	38.2	41.9	-	34.1	35.4	38.8	-	
S/T	0.70	0.58	0.40	-	0.72	0.60	0.42	-	0.74	0.62	0.43	-	0.77	0.64	0.44	-	0.79	0.66	0.46	-	0.80	0.67	0.46	-	
ΔT	20	17	13	-	20	17	13	-	20	17	13	-	20	17	13	-	20	17	13	-	19	16	12	-	
kW	2.73	2.79	2.88	-	2.94	3.01	3.10	-	3.13	3.20	3.30	-	3.29	3.37	3.48	-	3.43	3.51	3.63	-	3.55	3.63	3.76	-	
Amps	5.4	5.6	6.0	-	6.2	6.5	6.9	-	7.2	7.5	7.9	-	8.0	8.3	8.7	-	8.8	9.1	9.6	-	9.6	10.0	10.5	-	
Hi PR	203	219	231	-	228	245	259	-	259	279	295	-	296	318	336	-	332	358	378	-	367	395	417	-	
Lo PR	102	109	119	-	108	115	126	-	113	120	131	-	118	126	137	-	124	132	144	-	128	136	149	-	

75	MBh	47.3	48.7	52.8	56.6	46.2	47.6	51.5	55.3	45.1	46.5	50.3	54.0	44.0	45.3	49.1	52.7	41.8	43.1	46.6	50.0	38.7	39.9	43.2	46.3
	S/T	0.86	0.77	0.58	0.38	0.89	0.80	0.61	0.39	0.92	0.82	0.62	0.40	0.95	0.85	0.64	0.41	0.98	0.88	0.66	0.43	0.99	0.89	0.67	0.43
	ΔT	22	20	16	11	22	20	16	11	22	20	16	11	22	20	17	11	22	20	16	11	20	19	15	11
	kW	2.85	2.91	3.00	3.10	3.07	3.14	3.24	3.34	3.26	3.34	3.45	3.56	3.44	3.51	3.63	3.75	3.58	3.66	3.79	3.92	3.71	3.79	3.92	4.06
	Amps	5.9	6.1	6.5	6.9	6.7	7.0	7.4	7.9	7.7	8.0	8.5	9.0	8.6	8.9	9.4	9.9	9.5	9.8	10.3	10.9	10.3	10.7	11.2	11.8
	Hi PR	214	230	243	253	240	258	273	284	273	294	310	323	311	334	353	368	350	376	397	414	386	416	439	458
	Lo PR	108	115	125	133	114	121	132	141	118	126	137	146	124	132	144	154	130	139	151	161	135	143	157	167
	MBh	46.0	47.3	51.2	55.0	44.9	46.2	50.0	53.7	43.8	45.1	48.8	52.4	42.8	44.0	47.6	51.1	40.6	41.8	45.3	48.6	37.6	38.7	41.9	45.0
	S/T	0.82	0.74	0.56	0.36	0.85	0.76	0.58	0.37	0.87	0.78	0.59	0.38	0.90	0.81	0.61	0.39	0.94	0.84	0.63	0.41	0.94	0.84	0.64	0.41
	ΔT	22	21	17	12	23	21	17	12	23	21	17	12	23	21	17	12	23	21	17	12	21	19	16	11
kW	2.82	2.88	2.98	3.07	3.04	3.11	3.21	3.32	3.24	3.31	3.42	3.53	3.41	3.48	3.60	3.72	3.55	3.63	3.75	3.88	3.68	3.76	3.89	4.02	
Amps	5.8	6.0	6.4	6.8	6.6	6.9	7.3	7.7	7.6	7.9	8.3	8.8	8.5	8.8	9.3	9.8	9.3	9.7	10.2	10.7	10.2	10.5	11.1	11.7	
Hi PR	212	228	241	251	238	256	270	282	270	291	307	320	308	331	350	365	346	373	393	410	383	412	435	453	
Lo PR	107	114	124	132	113	120	131	139	117	125	136	145	123	131	143	152	129	137	150	160	133	142	155	165	
MBh	42.4	43.7	47.3	50.7	41.4	42.7	46.2	49.6	40.4	41.6	45.1	48.4	39.5	40.6	44.0	47.2	37.5	38.6	41.8	44.8	34.7	35.8	38.7	41.5	
S/T	0.79	0.71	0.54	0.35	0.82	0.74	0.56	0.36	0.84	0.75	0.57	0.37	0.87	0.78	0.59	0.38	0.90	0.81	0.61	0.39	0.91	0.81	0.62	0.40	
ΔT	23	21	17	12	23	21	17	12	23	21	17	12	23	21	18	12	23	21	17	12	21	20	16	11	
kW	2.76	2.81	2.90	3.00	2.97	3.03	3.13	3.23	3.16	3.23	3.33	3.44	3.32	3.40	3.51	3.63	3.46	3.54	3.66	3.78	3.59	3.67	3.79	3.92	
Amps	5.5	5.7	6.1	6.5	6.3	6.6	7.0	7.4	7.3	7.6	8.0	8.5	8.1	8.4	8.9	9.4	8.9	9.3	9.8	10.3	9.8	10.1	10.6	11.2	
Hi PR	205	221	233	243	230	248	262	273	262	282	298	311	299	321	339	354	336	361	382	398	371	399	422	440	
Lo PR	104	110	120	128	109	116	127	135	114	121	132	141	119	127	139	148	125	133	145	155	129	138	150	160	

IDB: Entering Indoor Dry Bulb Temperature kW = Total system power Shaded area is ACCA (TVA) conditions Amps = outdoor unit amps (comp.+fan)
 High and low pressures are measured at the liquid and suction service valves.

EXPANDED COOLING DATA — AS2160481A* / CA*F4860*6A* + TXV / MBE2000** -1 HIGH STAGE (CONT.)

IDB	Airflow	Outdoor Ambient Temperature																								
		65°F				75°F				85°F				95°F				105°F				115°F				
		59	63	67	71	59	63	67	71	59	63	67	71	59	63	67	71	59	63	67	71	59	63	67	71	
80	1744	MBh	48.2	49.2	52.6	56.2	47.1	48.1	51.4	54.9	45.9	46.9	50.1	53.6	44.8	45.8	48.9	52.3	42.6	43.5	46.5	49.7	39.4	40.3	43.1	46.0
		S/T	0.95	0.89	0.72	0.54	1.00	0.92	0.75	0.56	1.00	0.94	0.77	0.57	1.00	1.00	0.79	0.59	1.00	1.00	0.82	0.61	1.00	1.00	0.83	0.62
	ΔT	24	23	20	16	25	23	20	16	24	23	20	16	24	24	20	16	22	23	20	16	21	21	19	15	
	kW	2.87	2.93	3.03	3.12	3.09	3.16	3.26	3.37	3.29	3.36	3.48	3.59	3.47	3.54	3.66	3.79	3.61	3.70	3.82	3.95	3.74	3.83	3.96	4.09	
	Amps	6.0	6.2	6.6	7.0	6.8	7.1	7.5	8.0	7.9	8.2	8.6	9.1	8.7	9.1	9.5	10.1	9.6	10.0	10.4	11.0	10.5	10.8	11.4	12.0	
	Hi PR	216	232	245	256	242	261	275	287	276	297	313	327	314	338	357	372	353	380	401	419	390	420	443	463	
	Lo PR	109	116	126	135	115	122	134	142	120	127	139	148	126	134	146	155	132	140	153	163	136	145	158	168	
	MBh	46.8	47.8	51.1	54.6	45.7	46.7	49.9	53.3	44.6	45.6	48.7	52.0	43.5	44.5	47.5	50.8	41.3	42.2	45.1	48.2	38.3	39.1	41.8	44.7	
	S/T	0.90	0.85	0.69	0.51	0.94	0.88	0.71	0.53	0.96	0.90	0.73	0.55	0.99	0.93	0.76	0.56	1.00	0.96	0.78	0.59	1.00	0.97	0.79	0.59	
	ΔT	25	24	21	17	25	24	21	17	25	24	21	17	26	24	21	17	26	24	21	17	23	23	20	16	
kW	2.85	2.91	3.00	3.10	3.07	3.14	3.24	3.34	3.26	3.34	3.45	3.56	3.44	3.51	3.63	3.75	3.58	3.66	3.79	3.92	3.71	3.79	3.92	4.06		
Amps	5.9	6.1	6.5	6.9	6.7	7.0	7.4	7.9	7.7	8.0	8.5	9.0	8.6	8.9	9.4	9.9	9.5	9.8	10.3	10.9	10.3	10.7	11.2	11.8		
Hi PR	214	230	243	253	240	258	273	284	273	294	310	323	311	335	353	368	350	376	397	414	386	416	439	458		
Lo PR	108	115	125	133	114	121	132	141	118	126	137	146	124	132	144	154	130	139	151	161	135	143	157	167		
MBh	43.2	44.1	47.1	50.4	42.2	43.1	46.0	49.2	41.2	42.1	44.9	48.0	40.2	41.0	43.8	46.9	38.2	39.0	41.7	44.5	35.3	36.1	38.6	41.2		
S/T	0.87	0.82	0.66	0.50	0.90	0.85	0.69	0.51	0.92	0.87	0.71	0.53	0.95	0.89	0.73	0.54	0.99	0.93	0.76	0.57	1.00	0.94	0.76	0.57		
ΔT	25	24	21	17	26	25	21	17	26	25	21	17	26	25	22	17	26	25	21	17	24	23	20	16		
kW	2.78	2.84	2.93	3.02	2.99	3.06	3.16	3.26	3.18	3.25	3.36	3.47	3.35	3.43	3.54	3.66	3.49	3.57	3.69	3.82	3.62	3.70	3.82	3.95		
Amps	5.6	5.8	6.2	6.6	6.4	6.7	7.1	7.5	7.4	7.7	8.1	8.6	8.2	8.6	9.0	9.5	9.1	9.4	9.9	10.4	9.9	10.3	10.8	11.4		
Hi PR	207	223	236	246	233	251	265	276	265	285	301	314	302	324	343	357	339	365	385	402	375	403	426	444		
Lo PR	105	111	121	129	110	118	128	137	115	122	133	142	121	128	140	149	126	134	147	156	131	139	152	162		

85	1744	MBh	49.0	50.0	52.3	55.8	47.9	48.8	51.1	54.5	46.7	47.6	49.9	53.2	45.6	46.5	48.7	51.9	43.3	44.2	46.2	49.3	40.1	40.9	42.8	45.7
		S/T	0.99	0.96	0.86	0.70	1.00	0.99	0.90	0.73	1.00	1.00	0.92	0.74	1.00	1.00	0.95	0.77	1.00	1.00	0.98	0.80	1.00	1.00	0.99	0.80
	ΔT	26	25	24	21	25	26	24	21	25	25	24	21	24	25	24	21	24	23	24	21	21	22	22	19	
	kW	2.89	2.96	3.05	3.15	3.12	3.19	3.29	3.40	3.32	3.39	3.50	3.62	3.49	3.57	3.69	3.82	3.64	3.73	3.85	3.98	3.77	3.86	3.99	4.13	
	Amps	6.1	6.3	6.7	7.1	7.0	7.2	7.6	8.1	8.0	8.3	8.7	9.2	8.9	9.2	9.7	10.2	9.7	10.1	10.6	11.2	10.6	11.0	11.5	12.1	
	Hi PR	218	235	248	259	245	263	278	290	278	300	316	330	317	341	360	376	357	384	405	423	394	424	448	467	
	Lo PR	110	117	128	136	116	124	135	144	121	128	140	149	127	135	147	157	133	141	154	164	137	146	160	170	
	MBh	47.6	48.5	50.8	54.2	46.5	47.4	49.6	52.9	45.4	46.3	48.4	51.7	44.3	45.1	47.3	50.4	42.1	42.9	44.9	47.9	39.0	39.7	41.6	44.4	
	S/T	0.95	0.91	0.82	0.67	0.98	0.95	0.85	0.69	1.00	0.97	0.88	0.71	1.00	1.00	0.90	0.73	1.00	1.00	0.94	0.76	1.00	1.00	0.95	0.77	
	ΔT	27	26	25	21	27	27	25	22	27	27	25	22	26	27	25	22	26	27	25	22	23	24	23	20	
kW	2.87	2.93	3.03	3.12	3.09	3.16	3.26	3.37	3.29	3.36	3.48	3.59	3.47	3.54	3.66	3.79	3.61	3.70	3.82	3.95	3.74	3.83	3.96	4.09		
Amps	6.0	6.2	6.6	7.0	6.8	7.1	7.5	8.0	7.9	8.2	8.6	9.1	8.7	9.1	9.5	10.1	9.6	10.0	10.4	11.0	10.5	10.8	11.4	12.0		
Hi PR	216	232	245	256	242	261	275	287	276	297	313	327	314	338	357	372	353	380	401	419	390	420	443	463		
Lo PR	109	116	126	135	115	122	134	142	120	127	139	148	126	134	146	155	132	140	153	163	136	145	158	168		
MBh	43.9	44.8	46.9	50.0	42.9	43.7	45.8	48.9	41.9	42.7	44.7	47.7	40.9	41.7	43.6	46.5	38.8	39.6	41.4	44.2	36.0	36.7	38.4	41.0		
S/T	0.91	0.88	0.79	0.64	0.95	0.91	0.82	0.67	0.97	0.94	0.84	0.68	1.00	0.97	0.87	0.71	1.00	1.00	0.90	0.73	1.00	1.00	0.91	0.74		
ΔT	27	27	25	22	27	27	26	22	28	27	26	22	28	27	26	22	26	27	25	22	24	25	24	21		
kW	2.80	2.86	2.95	3.05	3.02	3.08	3.18	3.29	3.21	3.28	3.39	3.50	3.38	3.45	3.57	3.69	3.52	3.60	3.72	3.85	3.65	3.73	3.85	3.99		
Amps	5.7	5.9	6.3	6.7	6.5	6.8	7.2	7.6	7.5	7.8	8.2	8.7	8.4	8.7	9.1	9.7	9.2	9.5	10.0	10.6	10.0	10.4	10.9	11.5		
Hi PR	210	225	238	248	235	253	267	279	267	288	304	317	305	328	346	361	343	369	389	406	379	407	430	449		
Lo PR	106	112	123	131	112	119	130	138	116	123	135	143	122	130	141	151	128	136	148	158	132	140	153	163		

IDB: Entering Indoor Dry Bulb Temperature
 High and low pressures are measured at the liquid and suction service valves.
 kW = Total system power
 Shaded area is ARI Rating Conditions
 Amps = outdoor unit amps (comp.+fan)

EXPANDED COOLING DATA — ASZ160601A* / CA*F4860*6A* + TXV / MBE2000** -1 Low Stage

IDB	Airflow	Outdoor Ambient Temperature																											
		65°F				75°F				85°F				95°F				105°F				115°F							
		59	63	67	71	59	63	67	71	59	63	67	71	59	63	67	71	59	63	67	71	59	63	67	71				
		Entering Indoor Wet Bulb Temperature																											
		59	63	67	71	59	63	67	71	59	63	67	71	59	63	67	71	59	63	67	71	59	63	67	71	59	63	67	71
70	1350	MBh	39.8	41.3	45.2	-	38.9	40.3	44.2	-	38.0	39.4	43.1	-	37.0	38.4	42.1	-	35.2	36.5	40.0	-	32.6	33.8	37.0	-			
		S/T	0.72	0.61	0.42	-	0.75	0.63	0.43	-	0.77	0.64	0.45	-	0.79	0.66	0.46	-	0.82	0.69	0.48	-	0.83	0.69	0.48	-			
	ΔT	20	17	13	-	20	17	13	-	20	17	13	-	20	17	13	-	20	17	13	-	18	16	12	-				
	kW	2.45	2.51	2.59	-	2.65	2.71	2.80	-	2.83	2.89	2.99	-	2.98	3.05	3.16	-	3.12	3.19	3.30	-	3.23	3.31	3.42	-				
	Amps	9.5	9.7	10.0	-	10.2	10.5	10.8	-	11.1	11.4	11.8	-	11.9	12.2	12.6	-	12.7	13.0	13.4	-	13.4	13.8	14.2	-				
	Hi PR	207	222	235	-	232	250	264	-	264	284	300	-	301	323	341	-	338	364	384	-	374	402	424	-				
	Lo PR	104	111	121	-	110	117	128	-	114	122	133	-	120	128	139	-	126	134	146	-	130	138	151	-				
	MBh	38.7	40.1	43.9	-	37.8	39.1	42.9	-	36.9	38.2	41.9	-	36.0	37.3	40.8	-	34.2	35.4	38.8	-	31.6	32.8	35.9	-				
	S/T	0.69	0.58	0.40	-	0.72	0.60	0.41	-	0.73	0.61	0.42	-	0.76	0.63	0.44	-	0.79	0.66	0.46	-	0.79	0.66	0.46	-				
	ΔT	20	18	13	-	21	18	14	-	21	18	14	-	21	18	14	-	21	18	14	-	19	17	13	-				
kW	2.43	2.48	2.57	-	2.63	2.69	2.78	-	2.80	2.87	2.97	-	2.96	3.03	3.13	-	3.09	3.16	3.27	-	3.20	3.28	3.39	-					
Amps	9.4	9.6	9.9	-	10.1	10.4	10.7	-	11.0	11.3	11.7	-	11.8	12.1	12.5	-	12.6	12.9	13.3	-	13.3	13.6	14.1	-					
Hi PR	205	220	233	-	230	247	261	-	261	281	297	-	298	320	338	-	335	360	380	-	370	398	420	-					
Lo PR	103	110	120	-	109	116	126	-	113	120	131	-	119	126	138	-	125	133	145	-	129	137	150	-					
MBh	35.7	37.0	40.5	-	34.9	36.1	39.6	-	34.0	35.3	38.6	-	33.2	34.4	37.7	-	31.5	32.7	35.8	-	29.2	30.3	33.2	-					
S/T	0.67	0.56	0.39	-	0.69	0.58	0.40	-	0.71	0.59	0.41	-	0.73	0.61	0.42	-	0.76	0.63	0.44	-	0.76	0.64	0.44	-					
ΔT	21	18	14	-	21	18	14	-	21	18	14	-	21	18	14	-	21	18	14	-	20	17	13	-					
kW	2.37	2.42	2.50	-	2.56	2.62	2.71	-	2.73	2.79	2.89	-	2.88	2.95	3.05	-	3.01	3.08	3.18	-	3.12	3.19	3.30	-					
Amps	9.1	9.3	9.6	-	9.9	10.1	10.4	-	10.7	11.0	11.3	-	11.5	11.7	12.1	-	12.2	12.5	12.9	-	12.9	13.3	13.7	-					
Hi PR	199	214	226	-	223	240	253	-	253	273	288	-	289	311	328	-	325	349	369	-	359	386	408	-					
Lo PR	100	106	116	-	106	112	123	-	110	117	127	-	115	123	134	-	121	129	140	-	125	133	145	-					
75	1350	MBh	40.5	41.7	45.1	48.4	39.6	40.7	44.1	47.3	38.6	39.8	43.0	46.2	37.7	38.8	42.0	45.1	35.8	36.8	39.9	42.8	33.2	34.1	36.9	39.7			
		S/T	0.82	0.74	0.56	0.36	0.85	0.76	0.58	0.37	0.88	0.78	0.59	0.38	0.90	0.81	0.61	0.39	0.94	0.84	0.63	0.41	0.95	0.85	0.64	0.41			
	ΔT	23	21	17	12	23	21	17	12	23	21	17	12	23	21	17	12	23	21	17	12	21	20	16	11				
	kW	2.47	2.53	2.61	2.70	2.67	2.74	2.83	2.93	2.85	2.92	3.02	3.12	3.01	3.08	3.19	3.30	3.14	3.22	3.33	3.45	3.26	3.34	3.45	3.58				
	Amps	9.6	9.8	10.1	10.5	10.3	10.6	10.9	11.3	11.2	11.5	11.9	12.3	12.0	12.3	12.7	13.2	12.8	13.1	13.5	14.1	13.6	13.9	14.4	14.9				
	Hi PR	209	225	237	248	234	252	266	278	267	287	303	316	304	327	345	360	342	368	388	405	377	406	429	447				
	Lo PR	105	112	122	130	111	118	129	137	115	123	134	143	121	129	141	150	127	135	148	157	131	140	153	163				
	MBh	39.3	40.5	43.8	47.0	38.4	39.5	42.8	45.9	37.5	38.6	41.8	44.8	36.6	37.7	40.8	43.7	34.7	35.8	38.7	41.6	32.2	33.1	35.9	38.5				
	S/T	0.79	0.70	0.53	0.34	0.81	0.73	0.55	0.35	0.83	0.75	0.57	0.36	0.86	0.77	0.58	0.38	0.89	0.80	0.61	0.39	0.90	0.81	0.61	0.39				
	ΔT	24	22	18	12	24	22	18	12	24	22	18	12	24	22	18	13	24	22	18	12	22	20	17	12				
kW	2.45	2.51	2.59	2.68	2.65	2.71	2.80	2.90	2.83	2.89	2.99	3.10	2.98	3.05	3.16	3.27	3.12	3.19	3.30	3.42	3.23	3.31	3.42	3.54					
Amps	9.5	9.7	10.0	10.4	10.2	10.5	10.8	11.2	11.1	11.4	11.8	12.2	11.9	12.2	12.6	13.1	12.7	13.0	13.4	13.9	13.4	13.8	14.2	14.8					
Hi PR	207	223	235	245	232	250	264	275	264	284	300	313	301	323	342	356	338	364	384	401	374	402	425	443					
Lo PR	104	111	121	129	110	117	128	136	114	122	133	141	120	128	139	149	126	134	146	156	130	138	151	161					
MBh	36.3	37.4	40.4	43.4	35.4	36.5	39.5	42.4	34.6	35.6	38.6	41.4	33.8	34.8	37.6	40.4	32.1	33.0	35.7	38.4	29.7	30.6	33.1	35.5					
S/T	0.76	0.68	0.51	0.33	0.78	0.70	0.53	0.34	0.80	0.72	0.54	0.35	0.83	0.74	0.56	0.36	0.86	0.77	0.58	0.38	0.87	0.78	0.59	0.38					
ΔT	24	22	18	13	24	22	18	13	24	22	18	13	25	23	19	13	24	22	18	13	23	21	17	12					
kW	2.39	2.44	2.52	2.61	2.58	2.64	2.73	2.83	2.75	2.82	2.91	3.02	2.91	2.97	3.08	3.18	3.03	3.11	3.21	3.33	3.15	3.22	3.33	3.45					
Amps	9.2	9.4	9.7	10.1	10.0	10.2	10.5	10.9	10.8	11.1	11.5	11.9	11.6	11.9	12.3	12.7	12.3	12.6	13.0	13.5	13.1	13.4	13.8	14.4					
Hi PR	201	216	228	238	225	242	256	267	256	275	291	303	292	314	331	346	328	353	373	389	362	390	412	430					
Lo PR	101	107	117	125	107	113	124	132	111	118	129	137	116	124	135	144	122	130	142	151	126	134	147	156					

IDB: Entering Indoor Dry Bulb Temperature kW = Total system power Shaded area is ACCA (TVA) conditions Amps = outdoor unit amps (comp.+fan)
 High and low pressures are measured at the liquid and suction service valves.

EXPANDED COOLING DATA — ASZ160601A* / CA*F4860*6A* + TXV / MBE2000** -1 Low Stage (CONT.)

IDB	Airflow	Outdoor Ambient Temperature																								
		65°F				75°F				85°F				95°F				105°F				115°F				
		59	63	67	71	59	63	67	71	59	63	67	71	59	63	67	71	59	63	67	71	59	63	67	71	
80	1350	MBh	41.2	42.1	45.0	48.1	40.3	41.1	44.0	47.0	39.3	40.2	42.9	45.9	38.3	39.2	41.9	44.7	36.4	37.2	39.8	42.5	33.7	34.5	36.8	39.4
		S/T	0.90	0.85	0.69	0.52	0.94	0.88	0.71	0.53	0.96	0.90	0.73	0.55	1.00	0.93	0.76	0.57	1.00	0.96	0.79	0.59	1.00	1.00	0.79	0.59
	ΔT	25	24	21	17	26	25	21	17	26	25	21	17	26	25	22	17	25	24	21	17	23	23	20	16	
	kW	2.49	2.55	2.63	2.72	2.70	2.76	2.85	2.95	2.88	2.94	3.05	3.15	3.04	3.11	3.22	3.33	3.17	3.25	3.36	3.48	3.29	3.37	3.48	3.61	
	Amps	9.6	9.9	10.2	10.6	10.4	10.7	11.0	11.4	11.3	11.6	12.0	12.5	12.1	12.4	12.8	13.3	12.1	12.4	13.2	13.7	13.7	14.0	14.5	15.1	
	Hi PR	211	227	240	250	237	255	269	281	269	290	306	319	307	330	348	363	345	371	392	409	381	410	433	452	
	Lo PR	106	113	123	131	112	119	130	139	117	124	135	144	122	130	142	152	128	137	149	159	133	141	154	164	
	MBh	40.0	40.9	43.7	46.7	39.1	39.9	42.7	45.6	38.2	39.0	41.7	44.5	37.2	38.0	40.6	43.4	35.4	36.1	38.6	41.3	32.8	33.5	35.8	38.2	
	S/T	0.86	0.81	0.66	0.49	0.89	0.84	0.68	0.51	0.92	0.86	0.70	0.52	0.94	0.89	0.72	0.54	0.98	0.92	0.75	0.56	0.99	0.93	0.75	0.56	
	ΔT	26	25	22	18	27	26	22	18	27	26	22	18	27	26	22	18	27	25	22	18	25	24	21	17	
kW	2.47	2.53	2.61	2.70	2.67	2.74	2.83	2.93	2.85	2.92	3.02	3.12	3.01	3.08	3.19	3.30	3.14	3.22	3.33	3.45	3.26	3.34	3.45	3.58		
Amps	9.6	9.8	10.1	10.5	10.3	10.6	10.9	11.3	11.2	11.5	11.9	12.3	12.0	12.3	12.7	13.2	12.8	13.1	13.5	14.1	13.6	13.9	14.4	14.9		
Hi PR	209	225	237	248	234	252	266	278	267	287	303	316	304	327	345	360	342	368	388	405	377	406	429	447		
Lo PR	105	112	122	130	111	118	129	137	115	123	134	143	121	129	141	150	127	135	148	157	131	140	153	163		
MBh	36.9	37.7	40.3	43.1	36.1	36.9	39.4	42.1	35.2	36.0	38.4	41.1	34.4	35.1	37.5	40.1	32.6	33.4	35.6	38.1	30.2	30.9	33.0	35.3		
S/T	0.83	0.78	0.63	0.47	0.86	0.81	0.66	0.49	0.88	0.83	0.67	0.50	0.91	0.85	0.70	0.52	0.95	0.89	0.72	0.54	0.95	0.89	0.73	0.54		
ΔT	27	26	22	18	27	26	23	18	27	26	23	18	27	26	23	18	27	26	23	18	25	24	21	17		
kW	2.41	2.46	2.55	2.63	2.61	2.66	2.75	2.85	2.78	2.84	2.94	3.04	2.93	3.00	3.10	3.21	3.06	3.13	3.24	3.36	3.17	3.25	3.36	3.48		
Amps	9.3	9.5	9.8	10.2	10.0	10.3	10.6	11.0	10.9	11.2	11.6	12.0	11.7	12.0	12.4	12.8	12.4	12.7	13.2	13.7	13.2	13.5	14.0	14.5		
Hi PR	203	218	230	240	227	245	258	269	259	278	294	306	294	317	335	349	331	357	376	393	366	394	416	434		
Lo PR	102	109	118	126	108	115	125	133	112	119	130	139	118	125	137	146	123	131	143	152	128	136	148	158		

85	1350	MBh	41.9	42.7	44.8	47.8	41.0	41.8	43.7	46.7	40.0	40.8	42.7	45.5	39.0	39.8	41.6	44.4	37.1	37.8	39.6	42.2	34.3	35.0	36.7	39.1
		S/T	0.95	0.91	0.82	0.67	0.98	0.95	0.85	0.69	1.00	0.97	0.88	0.71	1.00	1.00	0.90	0.73	1.00	1.00	0.94	0.76	1.00	1.00	0.95	0.77
	ΔT	27	27	25	22	27	27	25	22	27	27	25	22	27	27	26	22	25	26	25	22	23	24	24	20	
	kW	2.51	2.57	2.66	2.75	2.72	2.78	2.88	2.98	2.90	2.97	3.07	3.18	3.06	3.13	3.24	3.36	3.20	3.27	3.39	3.51	3.32	3.40	3.51	3.64	
	Amps	9.7	10.0	10.3	10.7	10.5	10.8	11.1	11.6	11.4	11.7	12.1	12.6	12.2	12.5	13.0	13.5	13.0	13.4	13.8	14.3	13.8	14.2	14.6	15.2	
	Hi PR	213	229	242	253	239	257	272	283	272	293	309	322	310	333	352	367	348	375	396	413	385	414	437	456	
	Lo PR	107	114	125	133	113	121	132	140	118	125	137	146	124	132	144	153	130	138	151	160	134	143	156	166	
	MBh	40.7	41.5	43.5	46.4	39.8	40.5	42.5	45.3	38.8	39.6	41.4	44.2	37.9	38.6	40.4	43.1	36.0	36.7	38.4	41.0	33.3	34.0	35.6	38.0	
	S/T	0.90	0.87	0.79	0.64	0.94	0.90	0.82	0.66	0.96	0.93	0.84	0.68	0.99	0.96	0.86	0.70	1.00	0.99	0.90	0.73	1.00	1.00	0.90	0.73	
	ΔT	28	28	26	23	29	28	27	23	29	28	27	23	29	28	27	23	29	28	26	23	26	26	25	21	
kW	2.49	2.55	2.63	2.72	2.70	2.76	2.85	2.95	2.88	2.94	3.05	3.15	3.04	3.11	3.22	3.33	3.17	3.25	3.36	3.48	3.29	3.37	3.48	3.61		
Amps	9.6	9.9	10.2	10.6	10.4	10.7	11.0	11.4	11.3	11.6	12.0	12.5	12.1	12.4	12.8	13.3	12.9	13.2	13.7	14.2	13.7	14.0	14.5	15.1		
Hi PR	211	227	240	250	237	255	269	281	269	290	306	319	307	330	348	363	345	371	392	409	381	410	433	452		
Lo PR	106	113	123	131	112	119	130	139	117	124	135	144	122	130	142	152	128	137	149	159	133	141	154	164		
MBh	37.6	38.3	40.1	42.8	36.7	37.4	39.2	41.8	35.8	36.5	38.3	40.8	35.0	35.6	37.3	39.8	33.2	33.9	35.5	37.8	30.8	31.4	32.8	35.0		
S/T	0.87	0.84	0.76	0.62	0.90	0.87	0.79	0.64	0.93	0.89	0.81	0.65	0.96	0.92	0.83	0.67	0.99	0.96	0.86	0.70	1.00	0.96	0.87	0.71		
ΔT	28.7	28	27	23	29	29	27	23	29	29	27	23	29	29	27	23	29	28	27	23	27	26	25	22		
kW	2.43	2.48	2.57	2.65	2.63	2.69	2.78	2.87	2.80	2.87	2.97	3.07	2.96	3.03	3.13	3.24	3.09	3.16	3.27	3.39	3.20	3.28	3.39	3.51		
Amps	9.4	9.6	9.9	10.3	10.1	10.4	10.7	11.1	11.0	11.3	11.7	12.1	11.8	12.1	12.5	13.0	12.5	12.9	13.3	13.8	13.3	13.6	14.1	14.6		
Hi PR	205	220	233	243	230	247	261	272	261	281	297	310	297	320	338	353	335	360	380	397	370	398	420	438		
Lo PR	103	110	120	127	109	116	126	135	113	120	131	140	119	126	138	147	125	132	145	154	129	137	150	159		

IDB: Entering Indoor Dry Bulb Temperature
 High and low pressures are measured at the liquid and suction service valves.

kW = Total system power
 Shaded area is ARI Rating Conditions
 Amps = outdoor unit amps (comp.+fan)

EXPANDED COOLING DATA — ASZ160601A* / CA*F4860*6A* + TXV / MBE2000** -1 HIGH STAGE

IDB	Airflow	Outdoor Ambient Temperature																									
		65°F				75°F				85°F				95°F				105°F				115°F					
		59	63	67	71	59	63	67	71	59	63	67	71	59	63	67	71	59	63	67	71	59	63	67	71		
70	1350	MBh	55.9	57.9	63.4	-	54.6	56.5	62.0	-	53.3	55.2	60.5	-	52.0	53.9	59.0	-	49.4	51.2	56.1	-	45.7	47.4	51.9	-	
		S/T	0.74	0.62	0.43	-	0.77	0.64	0.44	-	0.79	0.66	0.46	-	0.81	0.68	0.47	-	0.84	0.70	0.49	-	0.85	0.71	0.49	-	
		ΔT	19	16	12	-	19	16	13	-	19	16	13	-	19	17	13	-	19	16	12	-	18	15	12	-	
	1200	kW	3.57	3.65	3.77	-	3.85	3.94	4.07	-	4.10	4.20	4.34	-	4.32	4.42	4.57	-	4.51	4.61	4.77	-	4.67	4.78	4.94	-	
		Amps	13.1	13.4	13.9	-	14.2	14.6	15.1	-	15.5	15.9	16.4	-	16.6	17.0	17.6	-	17.7	18.1	18.7	-	18.7	19.2	19.9	-	
		Hi/PR	214	230	243	-	240	258	273	-	273	294	310	-	311	334	353	-	350	376	397	-	386	416	439	-	
	1050	Lo/PR	101	107	117	-	107	113	124	-	111	118	129	-	116	124	135	-	122	130	142	-	126	134	146	-	
		MBh	54.2	56.2	61.6	-	53.0	54.9	60.1	-	51.7	53.6	58.7	-	50.4	52.3	57.3	-	47.9	49.7	54.4	-	44.4	46.0	50.4	-	
		S/T	0.71	0.59	0.41	-	0.73	0.61	0.42	-	0.75	0.63	0.43	-	0.78	0.65	0.45	-	0.80	0.67	0.47	-	0.81	0.68	0.47	-	
	75	1350	ΔT	20	17	13	-	20	17	13	-	20	17	13	-	20	17	13	-	20	17	13	-	20	17	12	-
			kW	3.54	3.62	3.74	-	3.82	3.91	4.04	-	4.07	4.16	4.30	-	4.29	4.38	4.53	-	4.47	4.58	4.73	-	4.63	4.74	4.90	-
			Amps	13.0	13.3	13.8	-	14.1	14.4	14.9	-	15.3	15.7	16.3	-	16.4	16.8	17.4	-	17.5	17.9	18.6	-	18.6	19.0	19.7	-
1200		Hi/PR	212	228	241	-	238	256	270	-	270	291	307	-	308	331	350	-	346	373	393	-	382	412	435	-	
		Lo/PR	100	106	116	-	106	112	123	-	110	117	127	-	115	123	134	-	121	128	140	-	125	133	145	-	
		MBh	50.1	51.9	56.8	-	48.9	50.7	55.5	-	47.7	49.5	54.2	-	46.6	48.3	52.9	-	44.2	45.8	50.2	-	41.0	42.5	46.5	-	
1050		S/T	0.68	0.57	0.39	-	0.71	0.59	0.41	-	0.72	0.60	0.42	-	0.75	0.62	0.43	-	0.78	0.65	0.45	-	0.78	0.65	0.45	-	
		ΔT	20	17	13	-	20	17	13	-	20	17	13	-	20	18	13	-	20	17	13	-	19	16	12	-	
		kW	3.46	3.53	3.64	-	3.73	3.81	3.93	-	3.97	4.06	4.19	-	4.18	4.27	4.42	-	4.36	4.46	4.61	-	4.51	4.62	4.77	-	
70		1350	Amps	12.6	13.0	13.4	-	13.7	14.0	14.5	-	14.9	15.3	15.8	-	16.0	16.4	16.9	-	17.0	17.4	18.0	-	18.0	18.5	19.1	-
			Hi/PR	205	221	233	-	230	248	262	-	262	282	298	-	298	321	339	-	336	361	382	-	371	399	422	-
			Lo/PR	97	103	112	-	102	109	119	-	106	113	124	-	112	119	130	-	117	125	136	-	121	129	141	-
	1200	MBh	56.8	58.5	63.3	67.9	55.5	57.1	61.8	66.4	54.2	55.8	60.4	64.8	52.8	54.4	58.9	63.2	50.2	51.7	55.9	60.0	46.5	47.9	51.8	55.6	
		S/T	0.84	0.75	0.57	0.37	0.87	0.78	0.59	0.38	0.90	0.80	0.61	0.39	0.92	0.83	0.63	0.40	0.96	0.86	0.65	0.42	0.97	0.87	0.65	0.42	
		ΔT	22	20	16	11	22	20	17	11	22	20	17	11	22	20	17	12	22	20	16	11	20	19	15	11	
	1050	kW	3.60	3.68	3.80	3.93	3.89	3.97	4.10	4.24	4.14	4.23	4.37	4.52	4.36	4.46	4.61	4.77	4.55	4.65	4.81	4.98	4.71	4.82	4.99	5.16	
		Amps	13.2	13.6	14.0	14.6	14.4	14.7	15.2	15.8	15.6	16.0	16.6	17.2	16.7	17.2	17.7	18.4	17.8	18.3	18.9	19.7	18.9	19.4	20.1	20.9	
		Hi/PR	216	232	245	256	242	261	275	287	276	297	313	327	314	338	357	372	353	380	401	419	390	420	443	463	
	75	1350	Lo/PR	102	108	118	126	108	115	125	133	112	119	130	138	118	125	136	145	123	131	143	152	127	136	148	158
			MBh	55.1	56.8	61.5	66.0	53.9	55.5	60.0	64.4	52.6	54.1	58.6	62.9	51.3	52.8	57.2	61.4	48.7	50.2	54.3	58.3	45.1	46.5	50.3	54.0
			S/T	0.80	0.72	0.54	0.35	0.83	0.74	0.56	0.36	0.85	0.76	0.58	0.37	0.88	0.79	0.60	0.38	0.91	0.82	0.62	0.40	0.92	0.83	0.62	0.40
1200		ΔT	23	21	17	12	23	21	17	12	23	21	17	12	23	21	17	12	23	21	17	12	21	20	16	11	
		kW	3.57	3.65	3.77	3.89	3.85	3.94	4.07	4.21	4.10	4.20	4.34	4.48	4.32	4.42	4.57	4.73	4.51	4.62	4.77	4.94	4.67	4.78	4.94	5.12	
		Amps	13.1	13.5	13.9	14.4	14.2	14.6	15.1	15.6	15.5	15.9	16.4	17.0	16.6	17.0	17.6	18.3	17.7	18.1	18.7	19.5	18.8	19.2	19.9	20.7	
1050		Hi/PR	214	230	243	253	240	258	273	284	273	294	310	323	311	335	353	368	350	376	397	414	386	416	439	458	
		Lo/PR	101	107	117	125	107	113	124	132	111	118	129	137	116	124	135	144	122	130	142	151	126	134	146	156	
		MBh	50.9	52.4	56.7	60.9	49.7	51.2	55.4	59.5	48.5	50.0	54.1	58.1	47.3	48.8	52.8	56.6	45.0	46.3	50.1	53.8	41.7	42.9	46.4	49.8	
70		S/T	0.77	0.69	0.52	0.34	0.80	0.72	0.54	0.35	0.82	0.74	0.56	0.36	0.85	0.76	0.58	0.37	0.88	0.79	0.60	0.38	0.89	0.80	0.60	0.39	
		ΔT	23	21	17	12	23	21	18	12	23	21	18	12	23	22	18	12	23	21	17	12	22	20	16	11	
		kW	3.48	3.56	3.67	3.80	3.76	3.84	3.97	4.10	4.00	4.09	4.23	4.37	4.21	4.31	4.45	4.61	4.40	4.50	4.65	4.81	4.55	4.66	4.82	4.98	
75	Amps	12.8	13.1	13.5	14.0	13.8	14.2	14.6	15.2	15.1	15.4	16.0	16.6	16.1	16.5	17.1	17.7	17.2	17.6	18.2	18.9	18.2	18.7	19.3	20.1		
	Hi/PR	207	223	236	246	233	250	265	276	265	285	301	314	302	324	343	357	339	365	385	402	375	403	426	444		
	Lo/PR	98	104	114	121	103	110	120	128	107	114	125	133	113	120	131	140	118	126	137	146	122	130	142	151		

IDB: Entering Indoor Dry Bulb Temperature kW = Total system power Shaded area is ACCA (TVA) conditions Amps = outdoor unit amps (comp.+fan)
 High and low pressures are measured at the liquid and suction service valves.

EXPANDED COOLING DATA — ASZ160601A* / CA*F4860*6A* + TXV / MBE2000** -1 HIGH STAGE (CONT.)

IDB	Airflow	Outdoor Ambient Temperature																									
		65°F				75°F				85°F				95°F				105°F				115°F					
		59	63	67	71	59	63	67	71	59	63	67	71	59	63	67	71	59	63	67	71	59	63	67	71		
80	1350	MBh	57.8	59.1	63.1	67.5	61.6	65.9	55.1	56.3	60.2	64.3	53.8	55.0	58.7	62.8	51.1	52.2	55.8	59.6	47.3	48.4	51.7	55.2			
		S/T	0.92	0.87	0.71	0.53	0.96	0.90	0.73	0.55	1.00	0.92	0.75	0.56	1.00	0.95	0.77	0.58	1.00	1.00	0.80	0.60	1.00	1.00	0.81	0.61	
		ΔT	24	23	20	16	25	24	20	16	25	24	20	16	24	24	21	16	24	24	20	16	21	22	19	15	
	1200	KW	3.63	3.71	3.83	3.96	3.92	4.01	4.14	4.28	4.17	4.27	4.41	4.56	4.40	4.50	4.65	4.81	4.59	4.70	4.86	5.02	4.76	4.86	5.03	5.21	
		Amps	13.4	13.7	14.2	14.7	14.5	14.8	15.4	15.9	15.8	16.2	16.7	17.4	16.9	17.3	17.9	18.6	18.0	18.5	19.1	19.8	19.1	19.6	20.3	21.1	
		Hi PR	218	235	248	259	245	263	278	290	278	300	316	330	317	341	360	376	357	384	405	423	394	424	448	467	
	1050	Lo PR	103	109	120	127	109	116	126	134	113	120	131	140	119	126	138	147	124	132	144	154	129	137	149	159	
		MBh	56.1	57.4	61.3	65.5	54.8	56.0	59.9	64.0	53.5	54.7	58.4	62.5	52.2	53.4	57.0	60.9	49.6	50.7	54.2	57.9	45.9	46.9	50.2	53.6	
		S/T	0.88	0.83	0.67	0.50	0.91	0.86	0.70	0.52	0.94	0.88	0.71	0.53	0.97	0.91	0.74	0.55	1.00	0.94	0.77	0.57	1.00	0.95	0.77	0.58	
	85	1350	ΔT	25	24	21	17	26	25	21	17	26	25	21	17	26	25	21	17	25	24	21	17	23	23	20	16
			KW	3.60	3.68	3.80	3.93	3.89	3.97	4.10	4.24	4.14	4.23	4.37	4.52	4.36	4.46	4.61	4.77	4.55	4.66	4.81	4.98	4.71	4.82	4.99	5.16
			Amps	13.3	13.6	14.0	14.6	14.4	14.7	15.2	15.8	15.6	16.0	16.6	17.2	16.7	17.2	17.7	18.4	17.8	18.3	18.9	19.7	18.9	19.4	20.1	20.9
1200		Hi PR	216	232	245	256	242	261	275	287	276	297	313	327	314	338	357	372	353	380	401	419	390	420	444	463	
		Lo PR	102	108	118	126	108	115	125	133	112	119	130	138	118	125	137	145	123	131	143	152	127	136	148	158	
		MBh	51.8	52.9	56.6	60.5	50.6	51.7	55.2	59.1	49.4	50.5	53.9	57.6	48.2	49.2	52.6	56.2	45.8	46.8	50.0	53.4	42.4	43.3	46.3	49.5	
1050		S/T	0.85	0.80	0.65	0.48	0.88	0.83	0.67	0.50	0.90	0.85	0.69	0.52	0.93	0.87	0.71	0.53	0.97	0.91	0.74	0.55	0.98	0.91	0.74	0.56	
		ΔT	26	25	21	17	26	25	22	17	26	25	22	17	26	25	22	17	26	25	22	17	24	23	20	16	
		KW	3.51	3.59	3.71	3.83	3.79	3.87	4.00	4.14	4.03	4.13	4.26	4.41	4.25	4.35	4.49	4.65	4.43	4.54	4.69	4.85	4.59	4.70	4.86	5.03	
85		Amps	12.9	13.2	13.6	14.2	14.0	14.3	14.8	15.3	15.2	15.6	16.1	16.7	16.3	16.7	17.2	17.9	17.3	17.8	18.4	19.1	18.4	18.9	19.5	20.3	
		Hi PR	210	225	238	248	235	253	267	279	267	288	304	317	305	328	346	361	343	369	389	406	379	407	430	449	
		Lo PR	99	105	115	122	104	111	121	129	109	115	126	134	114	121	132	141	119	127	139	148	124	131	144	153	
85	1350	MBh	58.8	60.0	62.8	67.0	57.5	58.6	61.3	65.4	56.1	57.2	59.9	63.9	54.7	55.8	58.4	62.3	52.0	53.0	55.5	59.2	48.2	49.1	51.4	54.8	
		S/T	0.97	0.93	0.84	0.68	1.00	0.97	0.87	0.71	1.00	0.99	0.90	0.73	1.00	1.00	0.93	0.75	1.00	1.00	0.96	0.78	1.00	1.00	0.97	0.79	
		ΔT	26	25	24	21	26	26	24	21	25	26	24	21	25	25	25	21	24	24	24	21	22	22	23	20	
	1200	KW	3.66	3.74	3.86	3.99	3.95	4.04	4.17	4.31	4.21	4.30	4.45	4.60	4.44	4.54	4.69	4.85	4.63	4.74	4.90	5.07	4.80	4.91	5.07	5.25	
		Amps	13.5	13.8	14.3	14.8	14.6	15.0	15.5	16.1	15.9	16.3	16.9	17.5	17.1	17.5	18.1	18.8	18.2	18.6	19.3	20.0	19.3	19.8	20.5	21.3	
		Hi PR	220	237	250	261	247	266	281	293	281	303	320	333	320	345	364	380	360	388	409	427	398	428	452	472	
	85	Lo PR	104	111	121	129	110	117	128	136	114	121	133	141	120	128	139	148	126	134	146	155	130	138	151	161	
		MBh	57.1	58.2	61.0	65.0	55.8	56.9	59.6	63.5	54.5	55.5	58.1	62.0	53.1	54.2	56.7	60.5	50.5	51.4	53.9	57.5	46.7	47.7	49.9	53.2	
		S/T	0.92	0.89	0.80	0.65	0.96	0.92	0.83	0.68	0.98	0.95	0.86	0.69	1.00	0.98	0.88	0.72	1.00	1.00	0.92	0.74	1.00	1.00	0.92	0.75	
	1050	ΔT	27	27	25	22	27	27	25	22	27	27	25	22	27	27	26	22	26	26	25	22	24	24	24	20	
		KW	3.63	3.71	3.83	3.96	3.92	4.01	4.14	4.28	4.17	4.27	4.41	4.56	4.40	4.50	4.65	4.81	4.59	4.70	4.86	5.02	4.76	4.86	5.03	5.21	
		Amps	13.4	13.7	14.2	14.7	14.5	14.8	15.4	15.9	15.8	16.2	16.7	17.4	16.9	17.3	17.9	18.6	18.0	18.5	19.1	19.8	19.1	19.6	20.3	21.1	
85	Hi PR	218	235	248	259	245	263	278	290	278	300	316	330	317	341	360	376	357	384	405	423	394	424	448	467		
	Lo PR	103	109	120	127	109	116	126	134	113	120	131	140	119	126	138	147	124	132	144	154	129	137	149	159		
	MBh	52.7	53.7	56.3	60.0	51.5	52.5	55.0	58.6	50.3	51.2	53.7	57.2	49.0	50.0	52.3	55.8	46.6	47.5	49.7	53.1	43.1	44.0	46.1	49.1		
85	S/T	0.89	0.86	0.78	0.63	0.92	0.89	0.80	0.65	0.95	0.91	0.82	0.67	0.98	0.94	0.85	0.69	1.00	0.98	0.88	0.72	1.00	0.99	0.89	0.72		
	ΔT	27	27	25	22	28	27	26	22	28	27	26	22	28	28	26	23	27	27	26	22	25	25	24	21		
	KW	3.54	3.62	3.74	3.86	3.82	3.91	4.03	4.17	4.07	4.16	4.30	4.44	4.29	4.38	4.53	4.69	4.47	4.57	4.73	4.89	4.63	4.74	4.90	5.07		
85	Amps	13.0	13.3	13.8	14.3	14.1	14.4	14.9	15.5	15.3	15.7	16.3	16.9	16.4	16.8	17.4	18.1	17.5	17.9	18.6	19.3	18.6	19.0	19.7	20.5		
	Hi PR	212	228	240	251	237	256	270	281	270	291	307	320	308	331	350	365	346	372	393	410	382	411	434	453		
	Lo PR	100	106	116	123	105	112	122	130	110	117	127	136	115	122	134	142	121	128	140	149	125	133	145	154		

IDB: Entering Indoor Dry Bulb Temperature
 High and low pressures are measured at the liquid and suction service valves.

kW = Total system power
 Shaded area is ARI Rating Conditions
 Amps = outdoor unit amps (comp.+fan)

PRODUCT SPECIFICATIONS

EXPANDED HEATING DATA — Low Stage

ASZ160241A* / CA*F3636*6A* + TXV / MBE1600** -1

Low Stage

	Outdoor Ambient Temperature																	
	65	60	55	50	47	45	40	35	30	25	20	17	15	10	5	0	-5	-10
MBh	20.8	19.7	18.5	17.3	16.6	16.0	14.9	13.7	13.1	12.1	11.1	10.5	10.1	9.1	8.1	7.0	6.0	4.9
ΔT	30.2	28.6	26.9	25.2	24.1	23.3	21.7	20.0	19.0	17.6	16.2	15.3	14.7	13.2	11.7	10.2	8.7	7.1
kW	1.42	1.40	1.37	1.34	1.32	1.31	1.28	1.25	1.37	1.33	1.30	1.28	1.27	1.23	1.20	1.17	1.14	1.10
Amps	6.8	6.3	5.9	5.6	5.4	5.3	5.0	4.7	4.5	4.3	4.1	4.0	4.0	3.8	3.5	3.3	3.1	2.8
COP	4.27	4.13	3.97	3.79	3.67	3.59	3.41	3.21	2.81	2.66	2.51	2.40	2.34	2.15	1.96	1.76	1.54	1.30
EER	14.6	14.1	13.6	13.0	12.5	12.3	11.6	11.0	9.6	9.1	8.6	8.2	8.0	7.4	6.7	6.0	5.3	4.5
Hi PR	360	345	331	317	309	304	292	280	268	256	246	240	236	227	218	209	202	195
Lo PR	150	139	130	119	113	109	100	89	80	72	63	59	56	48	41	35	30	24

ASZ160361A* / CA*F3642*6A* + TXV / MBE1600** -1

Low Stage

	Outdoor Ambient Temperature																	
	65	60	55	50	47	45	40	35	30	25	20	17	15	10	5	0	-5	-10
MBh	30.3	28.7	27.0	25.3	24.1	23.4	21.7	20.0	18.1	16.7	15.4	14.5	14.0	12.6	11.1	9.7	8.3	6.8
ΔT	35.1	33.2	31.3	29.2	27.9	27.1	25.1	23.2	21.0	19.4	17.8	16.8	16.2	14.5	12.9	11.2	9.6	7.9
kW	2.03	1.98	1.94	1.90	1.9	1.86	1.82	1.78	1.93	1.89	1.84	1.81	1.79	1.75	1.70	1.65	1.61	1.56
Amps	9.8	9.1	8.5	8.0	7.8	7.6	7.2	6.8	6.6	6.3	6.0	5.8	5.8	5.5	5.1	4.8	4.5	4.1
COP	4.38	4.23	4.07	3.89	3.76	3.68	3.49	3.29	2.74	2.60	2.45	2.35	2.29	2.11	1.92	1.72	1.51	1.27
EER	15.0	14.5	13.9	13.3	12.8	12.6	11.9	11.3	9.4	8.9	8.4	8.0	7.8	7.2	6.6	5.9	5.2	4.4
Hi PR	379	363	349	334	326	320	307	295	282	270	259	253	248	239	230	220	212	205
Lo PR	149	139	130	119	113	108	100	89	80	72	63	58	56	48	41	35	30	24

ASZ160481A* / CA*F4860*6A* +T XV / MBE2000** -1

Low Stage

	Outdoor Ambient Temperature																	
	65	60	55	50	47	45	40	35	30	25	20	17	15	10	5	0	-5	-10
MBh	43.2	40.9	38.5	36.0	34.4	33.3	30.9	28.5	25.7	23.7	21.8	20.6	19.9	17.8	15.8	13.8	11.8	9.6
ΔT	37.2	35.2	33.1	31.0	29.6	28.7	26.6	24.6	22.1	20.4	18.8	17.8	17.1	15.4	13.6	11.9	10.1	8.3
kW	2.97	2.91	2.85	2.79	2.8	2.72	2.66	2.60	2.71	2.65	2.58	2.54	2.52	2.45	2.38	2.32	2.25	2.18
Amps	14.1	13.1	12.2	11.5	11.1	10.9	10.3	9.7	9.3	8.9	8.5	8.3	8.1	7.7	7.2	6.8	6.3	5.6
COP	4.25	4.11	3.95	3.78	3.66	3.58	3.40	3.21	2.77	2.62	2.48	2.38	2.31	2.13	1.94	1.74	1.53	1.29
EER	14.5	14.0	13.5	12.9	12.5	12.2	11.6	11.0	9.5	9.0	8.5	8.1	7.9	7.3	6.6	5.9	5.2	4.4
Hi PR	411	394	379	362	354	347	334	320	307	293	281	275	270	259	249	239	231	223
Lo PR	145	135	126	116	110	105	97	86	78	70	61	57	55	46	40	34	29	23

ASZ160601A* / CA*F4860*6A* + TXV / MBE2000** -1

Low Stage

	Outdoor Ambient Temperature																	
	65	60	55	50	47	45	40	35	30	25	20	17	15	10	5	0	-5	-10
MBh	52.2	49.5	46.5	43.5	41.6	40.3	37.4	34.5	33.0	30.4	28.0	26.5	25.5	22.9	20.3	17.7	15.1	12.4
ΔT	40.3	38.2	35.9	33.6	32.1	31.1	28.9	26.6	25.4	23.5	21.6	20.4	19.7	17.6	15.6	13.6	11.6	9.5
kW	3.67	3.59	3.51	3.44	3.4	3.36	3.28	3.21	3.42	3.34	3.25	3.20	3.17	3.08	3.00	2.91	2.82	2.74
Amps	17.4	16.1	15.0	14.1	13.6	13.3	12.6	11.9	11.4	10.9	10.3	10.1	9.9	9.4	8.8	8.2	7.6	6.8
COP	4.16	4.03	3.88	3.71	3.59	3.51	3.33	3.15	2.82	2.67	2.52	2.42	2.35	2.17	1.98	1.78	1.56	1.32
EER	14.2	13.8	13.2	12.7	12.3	12.0	11.4	10.8	9.6	9.1	8.6	8.3	8.0	7.4	6.8	6.1	5.3	4.5
Hi PR	402	385	371	354	346	339	326	313	300	286	275	268	264	254	244	234	226	218
Lo PR	141	131	123	113	107	103	94	84	76	68	59	55	53	45	39	33	29	22

High pressure is measured at the suction service valve (the larger valve).

Low pressure is measured at the gauge port connection.

Amps = Outdoor unit amps (comp.+fan)

Calculations are based on nominal CFM and 70 °F indoor dry bulb.

kW = Total system power

Shaded area is ARI Rating Conditions at 47°F outdoor ambient temperature

EXPANDED HEATING DATA — HIGH STAGE

ASZ160241A* / CA*F3636*6A* + TXV / MBE1600**-1

High Stage

	Outdoor Ambient Temperature																	
	65	60	55	50	47	45	40	35	30	25	20	17	15	10	5	0	-5	-10
MBh	30.2	28.6	26.9	25.1	24.0	23.3	21.6	19.9	18.7	17.3	15.9	15.0	14.4	13.0	11.5	10.0	8.6	7.0
ΔT	31.9	30.2	28.4	26.6	25.4	24.6	22.9	21.1	19.8	18.3	16.8	15.9	15.3	13.7	12.2	10.6	9.0	7.4
kW	1.86	1.83	1.79	1.75	1.7	1.71	1.68	1.64	1.72	1.68	1.64	1.61	1.60	1.56	1.52	1.48	1.44	1.40
Amps	8.7	8.0	7.5	7.1	6.8	6.7	6.3	6.0	5.7	5.5	5.2	5.1	5.0	4.8	4.5	4.2	3.9	3.5
COP	4.74	4.58	4.40	4.20	4.06	3.97	3.77	3.55	3.18	3.01	2.84	2.72	2.65	2.44	2.22	1.99	1.74	1.47
EER	16.2	15.6	15.0	14.3	13.9	13.6	12.9	12.1	10.9	10.3	9.7	9.3	9.0	8.3	7.6	6.8	6.0	5.0
Hi PR	359	344	331	316	309	303	291	279	268	256	245	240	235	226	218	209	201	194
Lo PR	145	134	126	116	109	105	97	86	78	69	61	57	55	46	40	34	29	23

ASZ160361A* / CA*F3642*6A* + TXV / MBE1600**-1

High Stage

	Outdoor Ambient Temperature																	
	65	60	55	50	47	45	40	35	30	25	20	17	15	10	5	0	-5	-10
MBh	43.2	40.9	38.5	36.0	34.4	33.3	31.0	28.6	26.2	24.2	22.2	21.0	20.2	18.1	16.1	14.0	12.0	9.8
ΔT	34.8	33.0	31.0	29.0	27.7	26.8	24.9	23.0	21.1	19.4	17.9	16.9	16.3	14.6	13.0	11.3	9.6	7.9
kW	2.80	2.74	2.69	2.63	2.6	2.57	2.52	2.46	2.39	2.33	2.28	2.24	2.22	2.16	2.11	2.05	2.00	1.94
Amps	13.1	12.1	11.4	10.7	10.3	10.1	9.5	9.1	8.7	8.3	7.9	7.7	7.6	7.2	6.7	6.4	5.9	5.3
COP	4.52	4.37	4.20	4.01	3.88	3.79	3.60	3.40	3.21	3.03	2.86	2.74	2.66	2.45	2.23	2.00	1.75	1.48
EER	15.4	14.9	14.3	13.7	13.2	13.0	12.3	11.6	11.0	10.4	9.8	9.4	9.1	8.4	7.6	6.8	6.0	5.0
Hi PR	391	375	360	344	336	330	317	304	292	279	267	261	256	247	237	227	219	212
Lo PR	143	133	125	114	108	104	96	85	77	69	60	56	54	46	39	33	29	23

ASZ160481A* / CA*F4860*6A* +T XV / MBE2000**-1

High Stage

	Outdoor Ambient Temperature																	
	65	60	55	50	47	45	40	35	30	25	20	17	15	10	5	0	-5	-10
MBh	59.1	55.9	52.6	49.2	47.0	45.5	42.3	39.0	41.1	38.0	34.9	33.0	31.8	28.5	25.3	22.0	18.8	15.4
ΔT	35.3	33.4	31.4	29.4	28.1	27.2	25.3	23.3	24.6	22.7	20.9	19.7	19.0	17.0	15.1	13.2	11.2	9.2
kW	3.81	3.73	3.65	3.58	3.5	3.50	3.42	3.35	3.33	3.25	3.17	3.13	3.10	3.02	2.94	2.86	2.78	2.71
Amps	18.8	17.1	15.6	14.4	13.7	13.3	12.2	11.3	10.6	9.9	9.2	8.8	8.6	7.9	7.0	6.3	5.4	4.3
COP	4.54	4.39	4.22	4.03	3.89	3.81	3.61	3.41	3.61	3.42	3.22	3.09	3.00	2.77	2.52	2.25	1.98	1.67
EER	15.5	15.0	14.4	13.8	13.3	13.0	12.4	11.7	12.3	11.7	11.0	10.6	10.3	9.5	8.6	7.7	6.8	5.7
Hi PR	402	386	371	354	346	340	326	313	300	287	275	269	264	254	244	234	226	218
Lo PR	139	129	121	111	105	101	93	82	74	66	58	54	52	44	38	32	28	22

ASZ160601A* / CA*F4860*6A* + TXV / MBE2000**-1

High Stage

	Outdoor Ambient Temperature																	
	65	60	55	50	47	45	40	35	30	25	20	17	15	10	5	0	-5	-10
MBh	71.6	67.8	63.8	59.7	57.0	55.2	51.3	47.3	44.9	41.4	38.1	36.0	34.7	31.1	27.6	24.0	20.5	16.8
ΔT	36.9	34.9	32.8	30.7	29.3	28.4	26.4	24.3	23.1	21.3	19.6	18.5	17.8	16.0	14.2	12.4	10.6	8.6
kW	4.73	4.63	4.53	4.44	4.4	4.34	4.25	4.15	4.27	4.16	4.06	4.00	3.96	3.86	3.76	3.66	3.55	3.45
Amps	21.6	20.0	18.6	17.5	16.9	16.5	15.5	14.7	14.1	13.4	12.8	12.4	12.3	11.6	10.8	10.1	9.3	8.3
COP	4.44	4.29	4.12	3.94	3.81	3.73	3.54	3.34	3.08	2.91	2.75	2.63	2.56	2.36	2.15	1.92	1.69	1.42
EER	15.2	14.7	14.1	13.5	13.0	12.7	12.1	11.4	10.5	9.9	9.4	9.0	8.7	8.1	7.3	6.6	5.8	4.9
Hi PR	395	379	364	348	340	334	321	308	295	282	270	264	259	249	240	230	222	214
Lo PR	133	124	116	106	101	97	89	79	71	64	56	52	50	43	37	31	27	21

High pressure is measured at the suction service valve (the larger valve).

Low pressure is measured at the gauge port connection.

Amps = Outdoor unit amps (comp.+fan)

Calculations are based on nominal CFM and 70 °F indoor dry bulb.

kW = Total system power

Shaded area is ARI Rating Conditions at 47°F outdoor ambient temperature

ARI PERFORMANCE RATINGS

Outdoor Unit	Indoor Units		Furnace/ Blower	Cooling Capacity (BTU/h)			TVA Ratings ³			Heating Capacity			ARI #
	Indoor Coil			Total	Sens.	SEER ¹	EER ²	Total	Sens.	High	HSPF ⁴	Low	
ASZ16 0241A*	AEPF303616A*+TXV			24,000	19,000	16.00	12.50	22,200	18,900	23,000	9.50	15,000	1076093
	AEPF303616B*+TXV			24,000	19,000	16.00	12.50	22,200	18,900	23,000	9.50	15,000	1345655
	AEPF303616C*+TXV			24,000	19,000	16.00	12.50	22,200	18,900	23,000	9.50	15,000	1444024
	CA*F048*4*+MBE1600**-.1+TXV			24,000	19,000	16.00	12.50	22,200	18,900	23,000	9.50	15,000	1076089
	CA*F048*4*+TXV		A*V80905C**	24,000	19,000	16.00	12.50	22,200	18,900	23,000	9.50	15,000	1076097
	CA*F048*4*+TXV		A*V81155C**	24,000	19,000	16.00	12.50	22,200	18,900	23,000	9.50	15,000	1076099
	CA*F048*4*+TXV		A*V90704C**	24,000	19,000	16.00	12.50	22,200	18,900	23,000	9.50	15,000	1076092
	CA*F3636*6A*+MBE1200**-.1+TXV			24,000	19,000	16.00	12.50	22,200	18,900	24,000	9.50	15,000	1347421
	CA*F3636*6A*+MBE1600**-.1+TXV			24,000	19,000	16.00	12.50	22,200	18,900	23,000	9.50	15,000	1076090
	CA*F3636*6A*+TXV		A*V80905C**	24,000	19,000	16.00	12.50	22,200	18,900	23,000	9.50	15,000	1076096
	CA*F3636*6A*+TXV		A*V81155C**	24,000	19,000	16.00	12.50	22,200	18,900	23,000	9.50	15,000	1076098
	CA*F3636*6A*+TXV		A*V90453B**	23,000	18,200	15.50	12.00	21,300	18,100	24,000	9.50	15,000	1347420
	CA*F3636*6A*+TXV		A*V90704C**	24,000	19,000	16.00	12.50	22,200	18,900	23,000	9.50	15,000	1076091
	CA*F3636*6B*+MBE1200**-.1+TXV			24,000	19,000	16.00	12.50	22,200	18,900	24,000	9.50	15,000	1401110
	CA*F3636*6B*+MBE1600**-.1+TXV			24,000	19,000	16.00	12.50	22,200	18,900	23,000	9.50	15,000	1347424
	CA*F3636*6B*+TXV		A*V80905C**	24,000	19,000	16.00	12.50	22,200	18,900	23,000	9.50	15,000	1347425
	CA*F3636*6B*+TXV		A*V81155C**	24,000	19,000	16.00	12.50	22,200	18,900	23,000	9.50	15,000	1347426
	CA*F3636*6B*+TXV		A*V90453B**	23,000	18,200	15.50	12.00	21,300	18,100	24,000	9.50	15,000	1401109
	CA*F3636*6B*+TXV		A*V90704C**	24,000	19,000	16.00	12.50	22,200	18,900	23,000	9.50	15,000	1347427
	CA*F3636*6B*+TXV		G*V950704C**	24,000	19,000	16.00	12.50	22,200	18,900	23,000	9.50	15,000	1404317
CHPF3642*6A*+TXV		A*V80905C**	24,000	19,000	16.00	12.50	22,200	18,900	24,000	9.50	15,000	1076437	
CHPF3642*6A*+TXV		A*V81155C**	24,000	19,000	16.00	12.50	22,200	18,900	24,000	9.50	15,000	1076438	
CHPF3642*6A*+TXV		A*V90704C**	24,000	19,000	16.00	12.50	22,200	18,900	24,000	9.50	15,000	1076436	
CHPF3743C6A*+TXV		A*V80905C**	24,000	19,000	16.00	12.50	22,200	18,900	24,000	9.50	15,000	1347409	
CHPF3743C6A*+TXV		A*V81155C**	24,000	19,000	16.00	12.50	22,200	18,900	24,000	9.50	15,000	1347410	
CHPF3743C6A*+TXV		A*V90704C**	24,000	19,000	16.00	12.50	22,200	18,900	24,000	9.50	15,000	1347411	
CSCF3036N6A*+TXV		A*V80905C**	24,000	19,000	16.00	12.50	22,200	18,900	24,000	9.50	15,000	1076432	
CSCF3036N6A*+TXV		A*V81155C**	24,000	19,000	16.00	12.50	22,200	18,900	24,000	9.50	15,000	1076434	
CSCF3036N6A*+TXV		A*V90704C**	24,000	19,000	16.00	12.50	22,200	18,900	24,000	9.50	15,000	1076430	
CSCF3036N6B*+TXV		A*V80905C**	24,000	19,000	16.00	12.50	22,200	18,900	24,000	9.50	15,000	1347402	
CSCF3036N6B*+TXV		A*V81155C**	24,000	19,000	16.00	12.50	22,200	18,900	24,000	9.50	15,000	1347403	
CSCF3036N6B*+TXV		A*V90704C**	24,000	19,000	16.00	12.50	22,200	18,900	24,000	9.50	15,000	1347401	
H49F+TXV		A*V80905C**	24,000	19,000	16.00	12.50	22,200	18,900	24,000	9.50	15,000	1076433	
H49F+TXV		A*V81155C**	24,000	19,000	16.00	12.50	22,200	18,900	24,000	9.50	15,000	1076435	
H49F+TXV		A*V90704C**	24,000	19,000	16.00	12.50	22,200	18,900	24,000	9.50	15,000	1076431	

See Notes on Page 25.

ARI PERFORMANCE RATINGS (CONT.)

Outdoor Unit	Indoor Units		Cooling Capacity (BTU/h)				TVA Ratings ³			Heating Capacity		ARI #
	Indoor Coil	Furnace/Blower	Total	Sens.	SEER ¹	EER ²	Total	Sens.	High	HSPF ⁴	Low	
ASZ16 0361A*	AEPF426016A*+TXV		34,600	25,300	16.00	12.50	32,000	25,000	34,400	9.75	21,000	1076442
	AEPF426016B*+TXV		34,600	25,300	16.00	12.50	32,000	25,000	34,400	9.75	21,000	1345667
	AEPF426016C*+TXV		34,600	25,300	16.00	12.50	32,000	25,000	34,400	9.75	21,000	1492753
	CA*F060*4*+MBE1600**,-1+TXV		34,600	25,300	16.00	12.50	32,000	25,000	34,400	9.75	21,000	1076440
	CA*F060*4*+TXV	A*V90905D**	34,600	25,300	16.00	12.50	32,000	25,000	34,400	9.50	21,000	1076448
	CA*F060*4*+TXV	A*V91155D**	34,600	25,300	16.00	12.50	32,000	25,000	34,400	9.50	21,000	1076452
	CA*F3642*6A*+MBE1600**,-1+TXV		34,600	25,300	16.00	12.50	32,000	25,000	34,400	9.75	21,000	1076439
	CA*F3642*6A*+TXV	A*V80704B**	34,200	25,000	15.50	11.50	31,600	24,600	34,000	9.30	21,000	1347422
	CA*F3642*6A*+TXV	A*V90704C**	34,600	25,300	16.00	12.00	32,000	25,000	34,000	9.30	21,000	1191371
	CA*F3642*6A*+TXV	A*V90905D**	34,600	25,300	16.00	12.50	32,000	25,000	34,400	9.50	21,000	1076447
	CA*F3642*6A*+TXV	A*V91155D**	34,600	25,300	16.00	12.50	32,000	25,000	34,400	9.50	21,000	1076451
	CA*F3743*6A*+MBE1600**,-1+TXV		34,600	25,300	16.00	12.50	32,000	25,000	34,400	9.75	21,000	1347428
	CA*F3743*6A*+TXV	A*V80704B**	34,200	25,000	15.50	11.50	31,600	24,600	34,000	9.30	21,000	1401111
	CA*F3743*6A*+TXV	A*V90704C**	34,600	25,300	16.00	12.00	32,000	25,000	34,000	9.30	21,000	1347436
	CA*F3743*6A*+TXV	A*V90905D**	34,600	25,300	16.00	12.50	32,000	25,000	34,400	9.50	21,000	1347429
	CA*F3743*6A*+TXV	A*V91155D**	34,600	25,300	16.00	12.50	32,000	25,000	34,400	9.50	21,000	1347430
	CA*F3743*6A*+TXV	G*V950704C**	34,600	25,300	16.00	12.00	32,000	25,000	34,000	9.30	21,000	1404325
	CA*F3743*6A*+TXV	G*V950905D**	34,600	25,300	16.00	12.50	32,000	25,000	34,400	9.50	21,000	1404328
	CA*F3743*6A*+TXV	G*V951155D**	34,600	25,300	16.00	12.50	32,000	25,000	34,400	9.50	21,000	1404331
	CA*F4860*6A*+MBE2000**,-1+TXV		35,800	26,100	15.50	11.50	33,100	25,800	34,000	9.30	21,000	1430200
CHPF048*4*+MBE1600**,-1+TXV		34,600	25,300	16.00	12.50	32,000	25,000	34,400	9.50	21,000	1076453	
CHPF048*4*+TXV		34,600	25,300	16.00	12.50	32,000	25,000	34,400	9.50	21,000	1076454	
CHPF048*4*+TXV	A*V81155C**	34,200	25,000	15.50	12.00	31,600	24,600	34,000	9.50	20,400	1076475	
CHPF048*4*+TXV	A*V90905D**	34,600	25,300	16.00	12.50	32,000	25,000	34,400	9.50	21,000	1076470	
CHPF048*4*+TXV	A*V91155D**	34,600	25,300	16.00	12.50	32,000	25,000	34,400	9.50	21,000	1076474	
CHPF3642*6A*+MBE1600**,-1+TXV		34,600	25,300	16.00	12.50	32,000	25,000	34,400	9.50	21,000	1076455	
CHPF3642*6A*+MBE2000**,-1+TXV		34,600	25,300	16.00	12.50	32,000	25,000	34,400	9.50	21,000	1076456	
CHPF3642*6A*+TXV	A*V90905D**	34,600	25,300	16.00	12.50	32,000	25,000	34,400	9.50	21,000	1076469	
CHPF3642*6A*+TXV	A*V91155D**	34,600	25,300	16.00	12.50	32,000	25,000	34,400	9.50	21,000	1076473	
CHPF3743C6A*+MBE1600**,-1A*+TXV		34,600	25,300	16.00	12.50	32,000	25,000	34,400	9.50	21,000	1347412	
CHPF3743D6A*+MBE2000**,-1A*+TXV		34,600	25,300	16.00	12.50	32,000	25,000	34,400	9.50	21,000	1347413	
CHPF3743D6A*+TXV	A*V90905D**	34,600	25,300	16.00	12.50	32,000	25,000	34,400	9.50	21,000	1347414	
CHPF3743D6A*+TXV	A*V91155D**	34,600	25,300	16.00	12.50	32,000	25,000	34,400	9.50	21,000	1347415	
CSCF3642N6A*+TXV	A*V90905D**	34,600	25,300	16.00	12.50	32,000	25,000	34,400	9.50	21,000	1076519	
CSCF3642N6A*+TXV	A*V91155D**	34,600	25,300	16.00	12.50	32,000	25,000	34,400	9.50	21,000	1076517	
CSCF3642N6C*+TXV	A*V90905D**	34,600	25,300	16.00	12.50	32,000	25,000	34,400	9.50	21,000	1347408	
CSCF3642N6C*+TXV	A*V91155D**	34,600	25,300	16.00	12.50	32,000	25,000	34,400	9.50	21,000	1347407	
H60F+TXV	A*V90905D**	34,600	25,300	16.00	12.50	32,000	25,000	34,400	9.50	21,000	1076520	
H60F+TXV	A*V91155D**	34,600	25,300	16.00	12.50	32,000	25,000	34,400	9.50	21,000	1076518	

See Notes on Page 25.

ARI PERFORMANCE RATINGS (CONT.)

Outdoor Unit	Indoor Units		Cooling Capacity (BTU/h)				TVA Ratings ³			Heating Capacity			ARI #
	Indoor Coil	Furnace/ Blower	Total	Sens.	SEER ¹	EER ²	Total	Sens.	High	HSPF ⁴	Low		
ASZ16 0481A*	AEPF426016A**+TXV		46,000	35,000	15.50	12.00	42,600	34,500	46,000	9.50	34,000	1076477	
	AEPF426016B**+TXV		46,000	35,000	15.50	12.00	42,600	34,500	46,000	9.50	34,000	1345658	
	AEPF426016C**+TXV		46,000	35,000	15.50	12.00	42,600	34,500	46,000	9.50	34,000	1492754	
	CA*F4860*6A**+MBE2000**,-1+TXV		47,500	36,100	16.00	13.00	43,900	35,600	47,000	9.75	34,000	1076476	
	CA*F4860*6A**+TXV	A*V80905C**	47,000	35,700	15.50	12.00	43,500	35,200	46,000	9.50	34,000	1347423	
	CA*F4860*6A**+TXV	A*V81155C**	47,500	36,100	15.50	12.00	43,900	35,600	46,000	9.50	34,000	1444026	
	CA*F4860*6A**+TXV	A*V90704C**	47,500	36,100	16.00	12.50	43,900	35,600	47,000	9.50	34,000	1486568	
	CA*F4860*6A**+TXV	A*V90905D**	47,500	36,100	16.00	12.50	43,900	35,600	47,000	9.50	34,000	1076479	
	CA*F4860*6A**+TXV	A*V91155D**	47,500	36,100	16.00	13.00	43,900	35,600	47,000	9.75	34,000	1076478	
	CA*F4961*6A**+MBE2000**,-1+TXV		47,500	36,100	16.00	12.00	43,900	35,200	46,000	9.50	34,000	1347437	
	CA*F4961*6A**+TXV	A*V80905C**	47,000	35,700	15.50	12.00	43,500	35,600	46,000	9.50	34,000	1401112	
	CA*F4961*6A**+TXV	A*V81155C**	47,500	36,100	15.50	12.00	43,900	35,600	46,000	9.50	34,000	1444027	
	CA*F4961*6A**+TXV	A*V90704C**	47,500	36,100	16.00	12.50	43,900	35,600	47,000	9.50	34,000	1486569	
	CA*F4961*6A**+TXV	A*V90905D**	47,500	36,100	16.00	12.50	43,900	35,600	47,000	9.50	34,000	1347431	
	CA*F4961*6A**+TXV	A*V91155D**	47,500	36,100	16.00	12.50	43,900	35,600	47,000	9.50	34,000	1347432	
	CA*F4961*6A**+TXV	G*V950905D**	47,500	36,100	16.00	12.50	43,900	35,600	47,000	9.50	34,000	1404333	
	CA*F4961*6A**+TXV	G*V951155D**	47,500	36,100	16.00	12.50	43,900	35,600	47,000	9.50	34,000	1404336	
	CHPF060D4**+TXV	A*V90905D**	47,500	36,100	16.00	12.50	43,900	35,600	47,000	9.50	34,000	1076503	
	CHPF060D4**+TXV	A*V91155D**	47,500	36,100	16.00	12.50	43,900	35,600	47,000	9.50	34,000	1076505	
	CHPF4860*6A**+MBE2000**,-1+TXV		47,500	36,100	16.00	12.50	43,900	35,600	47,000	9.75	34,000	1076497	
CHPF4860D6A**+TXV	A*V90905D**	47,500	36,100	16.00	12.50	43,900	35,600	47,000	9.50	34,000	1076502		
CHPF4860D6A**+TXV	A*V91155D**	47,500	36,100	16.00	12.50	43,900	35,600	47,000	9.50	34,000	1076504		
CHPF4860D6C**+TXV		47,500	36,100	16.00	12.50	43,900	35,600	47,000	9.50	34,000	1347416		
CHPF4860D6C**+TXV	A*V90905D**	47,500	36,100	16.00	12.50	43,900	35,600	47,000	9.50	34,000	1347417		
CHPF4860D6C**+TXV	A*V91155D**	47,500	36,100	16.00	12.50	43,900	35,600	47,000	9.50	34,000	1347418		
CSCF4860N6A**+TXV	A*V90905D**	47,500	36,100	16.00	12.50	43,900	35,600	47,000	9.50	34,000	1076506		
CSCF4860N6A**+TXV	A*V91155D**	47,500	36,100	16.00	12.50	43,900	35,600	47,000	9.50	34,000	1076508		
CSCF4860N6C**+TXV	A*V90905D**	47,500	36,100	16.00	12.50	43,900	35,600	47,000	9.50	34,000	1347404		
CSCF4860N6C**+TXV	A*V91155D**	47,500	36,100	16.00	12.50	43,900	35,600	47,000	9.50	34,000	1347405		
H61F+TXV	A*V90905D**	47,500	36,100	16.00	12.50	43,900	35,600	47,000	9.50	34,000	1076507		
H61F+TXV	A*V91155D**	47,500	36,100	16.00	12.50	43,900	35,600	47,000	9.50	34,000	1076509		

ARI PERFORMANCE RATINGS (CONT.)

Outdoor Unit	Indoor Units		Cooling Capacity (BTU/h)				TVA Ratings ³		Heating Capacity			ARI #
	Indoor Coil	Furnace/ Blower	Total	Sens.	SEER ¹	EER ²	Total	Sens.	High	HSPF ⁴	Low	
ASZ16 0601A*	AEPF426016A*+TXV		57,000	42,200	15.00	12.00	52,700	41,600	57,000	9.00	36,400	1191372
	AEPF426016B*+TXV		57,000	42,200	15.00	12.00	52,700	41,600	57,000	9.00	36,400	1345653
	AEPF426016C*+TXV		57,000	42,200	15.00	12.00	52,700	41,600	57,000	9.00	36,400	1492760
	CA*F4860*6A*+MBE2000** ⁻¹ +TXV		57,000	42,200	16.00	12.20	52,700	41,600	57,000	9.75	36,000	1076512
	CA*F4860*6A*+TXV	A*V90905D**	57,000	42,200	15.00	12.00	52,700	41,600	57,000	9.25	36,000	1076514
	CA*F4860*6A*+TXV	A*V91155D**	57,000	42,200	15.00	12.00	52,700	41,600	57,000	9.25	36,000	1076515
	CA*F4961*6A*+MBE2000** ⁻¹ +TXV		57,000	42,200	16.00	12.20	52,700	41,600	57,000	9.75	36,000	1347433
	CA*F4961*6A*+TXV	A*V90905D**	57,000	42,200	15.00	12.00	52,700	41,600	57,000	9.25	36,000	1347434
	CA*F4961*6A*+TXV	A*V91155D**	57,000	42,200	15.00	12.00	52,700	41,600	57,000	9.25	36,000	1347435
	CA*F4961*6A*+TXV	G*V950905D**	57,000	42,200	15.00	12.00	52,700	41,600	57,000	9.25	36,000	1404338
	CA*F4961*6A*+TXV	G*V951155D**	57,000	42,200	15.00	12.00	52,700	41,600	57,000	9.25	36,000	1404340
	CHPF4860*6A*+MBE2000** ⁻¹ +TXV		57,000	42,200	16.00	12.20	52,700	41,600	57,000	9.35	36,000	1076513
	CHPF4860D6C*+MBE2000** ⁻¹ A*+TXV		57,000	42,200	16.00	12.20	52,700	41,600	57,000	9.35	36,000	1347419
	CSCF4860N6A*+TXV	A*V91155D**	57,000	42,200	15.00	12.00	52,700	41,600	57,000	9.25	36,000	1076516
CSCF4860N6C*+TXV	A*V91155D**	57,000	42,200	15.00	12.00	52,700	41,600	57,000	9.25	36,000	1347406	

¹ Seasonal Energy Efficiency Ratio; Certified per ARI 210/240 @ 80°F/ 67°F/ 95°F
³ TVA Rating: BTU/h @ 75°F/ 63°F - 95°F

² Energy Efficiency Ratio @ 80°F/ 67°F/ 95°F
⁴ HSPF = Heating Seasonal Performance Factor

Notes:

- Always check the S&R plate for electrical data on the unit being installed.
- When matching the outdoor unit to the indoor unit, use the piston supplied with the outdoor unit or that specified on the piston kit chart supplied with the indoor unit.
- EEP - Order from Service Dept. Part No. B13707-38 or new Solid State Board B13707-35S. Part No. B13707-38 is not interchangeable with B13707-35S. The Goodman Gas Furnace contains the EEP cooling time delay

DIMENSIONS

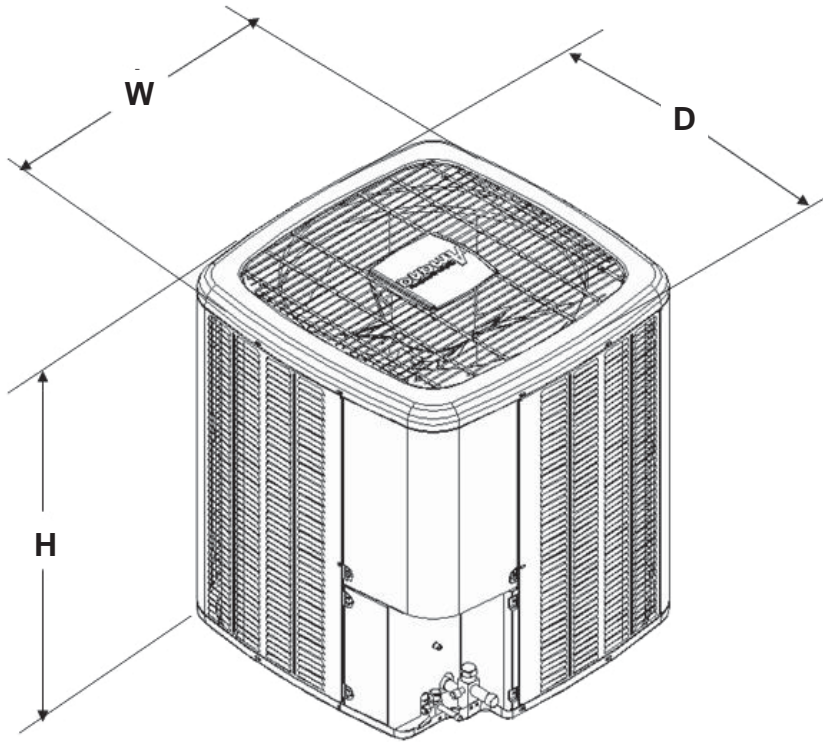

Model	Dimensions
ASZ160241A	29x29x38¼
ASZ160361A	35½x35½x38¼
ASZ160481A	35½x35½x38¼
ASZ160481B	35½x35½x34¼
ASZ160601A	35½x35½x38¼

ASZ16 WIRING DIAGRAM

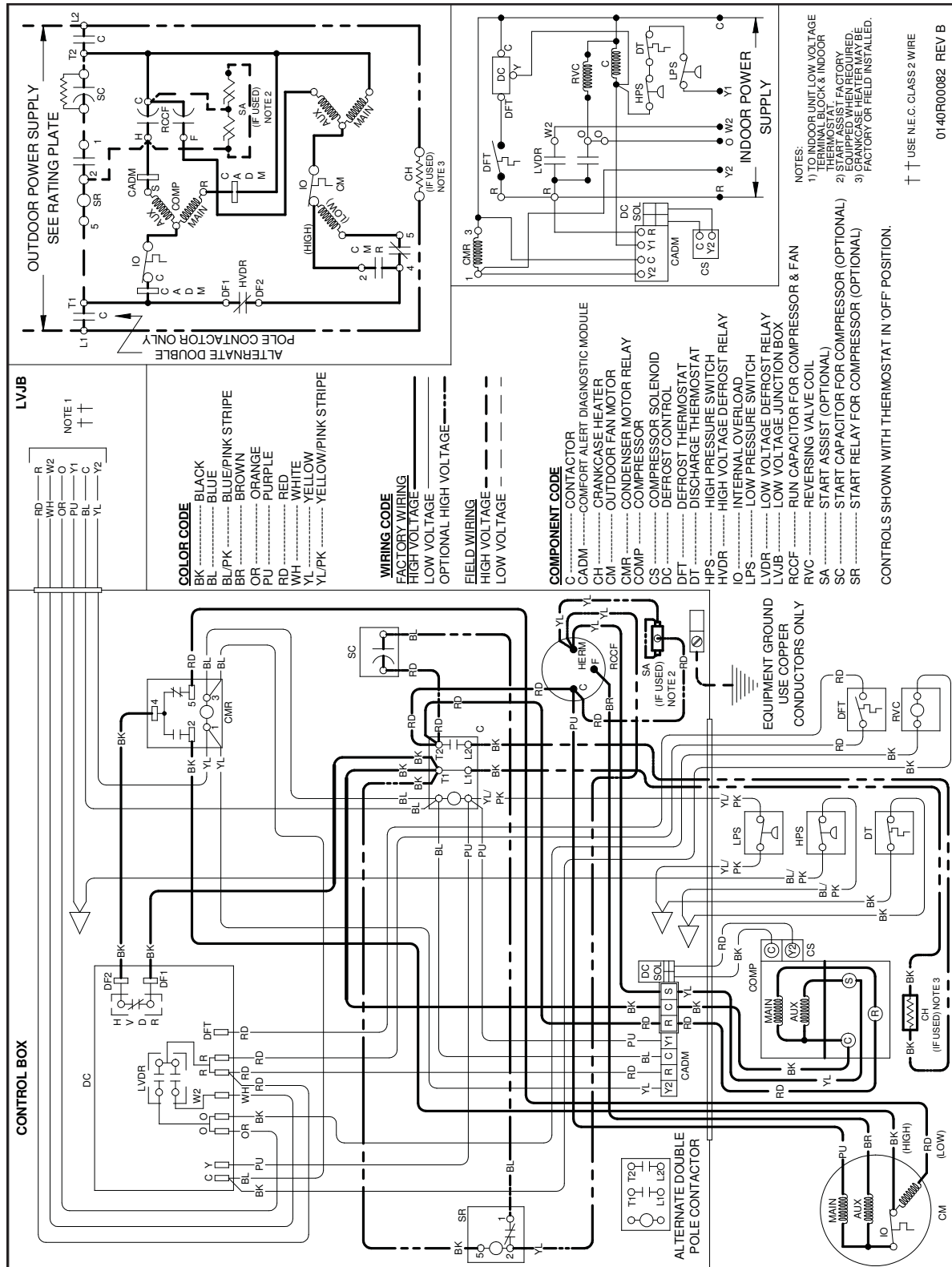

WARNING

High Voltage:

Disconnect all power before servicing or installing this unit. Multiple power sources may be present. Failure to do so may cause property damage, personal injury, or death.



Wiring is subject to change. Always refer to the wiring diagram of the unit for the most up-to-date wiring.

ACCESSORIES

Model	Description	ASZ16 024	ASZ16 030	ASZ16 036	ASZ16 042	ASZ16 048	ASZ16 060
ABK-20	Anchor Bracket Kit ▼	X	X	X	X	X	X
ASC01	Anti-Short Cycle Kit	X	X	X	X	X	X
CSR-U-1	Hard-start Kit	X	X	X			
CSR-U-2	Hard-start Kit			X	X	X	X
CSR-U-3	Hard-start Kit					X	X
FSK01A ¹	Freeze Protection Kit	X	X	X	X	X	X
OT18-60A ²	Outdoor Thermostat w/ Lockout Stat	X	X	X	X	X	X
TX2N4 ³	TXV Kit	X					
TX3N4 ³	TXV Kit		X	X			
TX5N4 ³	TXV Kit				X	X	X

▼ Contains 20 brackets; four brackets needed to anchor unit to pad

¹ Installed on indoor coil

² Required for heat pump applications where ambient temperatures fall below 0° F with 50% or higher relative humidity.

³ Field-installed, non-bleed, expansion valve kit — Condensing units and heat pumps with reciprocating compressors require the use of start-assist components when used in conjunction with an indoor coil using a non-bleed thermal expansion valve refrigerant metering device.

